

A172.8-UG Series / A172.8-UG-VR Series & A172.8-UG-SO Series
Universal Bi-Level, Barrier Free, Wall Mounted Water Cooler



A172408F-UG-VR



A172108F-UG



A172108S-UG-SO



A172108F-UG / A178408F-UG / A172108S-UG / A172408S-UG
172108F-UG-VR / A172408F-UG-VR / A172108S-UG-VR / A172408S-UG-VR
A172108F-UG-SO / A172408F-UG-SO / A172108S-UG-SO / A172408S-UG-SO

TECHNICAL ASSISTANCE TOLL FREE TELEPHONE NUMBER:

1.800.591.9360

Technical Assistance E-Mail: fieldservice@acorneng.com

NOTES TO INSTALLER:

- 1. Please leave this documentation with the owner of the fixture when finished.**
- 2. Please read this entire booklet before beginning the installation.**
- 3. Check your installation for compliance with plumbing, electrical and other applicable codes.**
- 4. IMPORTANT: Water supply to unit from RO Reverse Osmosis filtration systems will damage fixture components and void product Warranty.**

Murdock assumes no responsibility for use of void or suspended data. © Copyright Murdock, City of Industry, CA Member of Morris Group International. Please visit www.murdockmfg.com for most current specifications.

COMPLIES WITH
STANDARDS



NSF/ANSI/CAN 61

ANSI/ASHRAE 18

murdock[®]
SINCE 1853

15125 Proctor Ave, City of Industry,
CA, 91746 U.S.A.
Phone 800-453-7465

Member of



IMPORTANT

This Fixture is intended for indoor use only** and is not suitable for installation in an area where a water jet could be used as well as in environments where freezing may occur. This fixture dispenses water that has been lowered in temperature, but otherwise remains unchanged by the materials in the Water Cooler. It is common for electrical equipment to be grounded to water lines either within a structure or away from it. Every attempt should be made to prevent this kind of grounding from generating electrical feedback into the Water Cooler creating electrolysis. Electrolysis will cause a metallic taste or cause water metal content to increase. **NOTE:** A Dielectric Coupling must be used to connect the Water Cooler to the water supply. A nonmetallic Coupler is furnished with this Water Cooler to meet this requirement.

****NOTE:** -VR Series units are rated for outdoors. Refer to page 5 for complete details and requirements.

ROUGHING-IN AND DIMENSIONAL DRAWING

Prior to roughing-in, consult with local, state, and federal codes for proper mounting height. All installation and service may only be performed by authorized personnel. No unauthorized persons shall have access to the service area.

Mounting Carrier: Refer to Installation details provided by Carrier manufacturer when unit is to be installed with In-W all Mounting Carrier (provided by others). **Compatible J.R. Smith[®] brand Carrier model is Figure # 0834-4P.**

A172.8-UG Series Universal Bi-Level Wall Mounted Water Cooler

(Standard Configuration Left Unit High with Right Unit Low. Rough-ins are the same for -SO and -VR models)

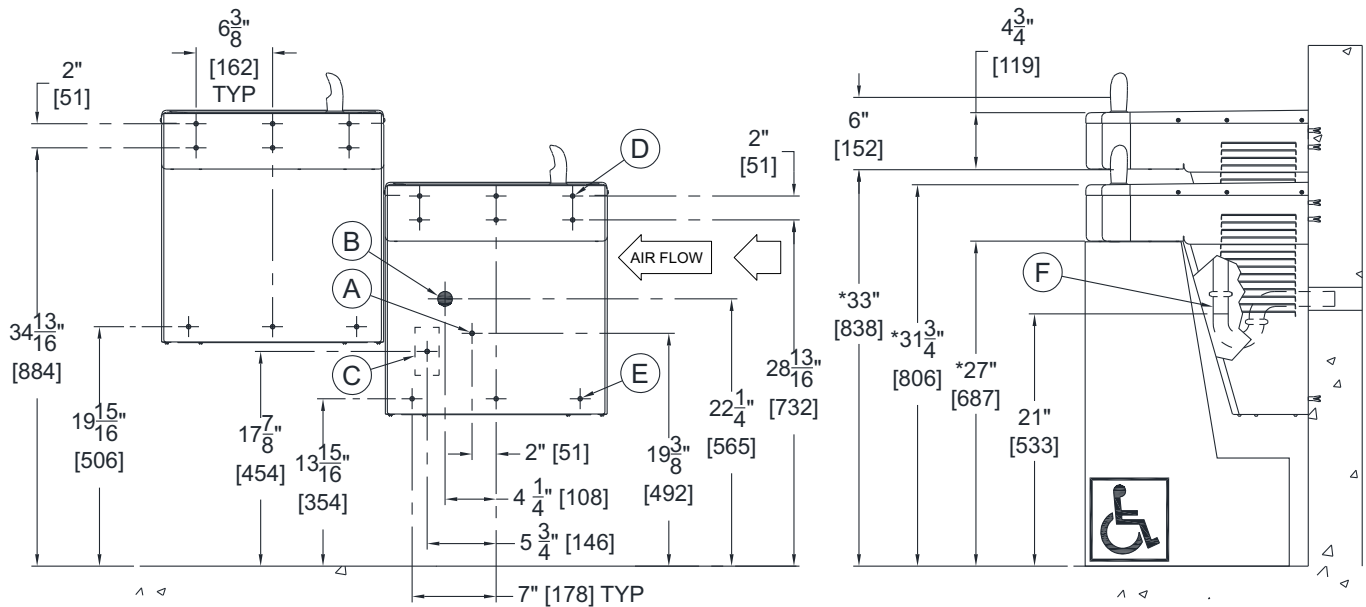

GENERAL NOTES:

1. ALL DIMENSIONS ARE IN INCHES [MM]
2. ALLOW 4 INCHES [102MM] MINIMUM CLEARANCE PER SIDE FOR VENTILATION
- *3. DIMENSIONS SHOWN ARE FOR ADA ADULT HEIGHT. ADJUST VERTICAL DIMENSIONS AS NECESSARY TO COMPLY WITH FEDERAL, STATE & LOCAL CODES
4. STOP VALVE, P-TRAP & ELECTRICAL OUTLET NOT SUPPLIED
5. IMPORTANT: COOLERS MUST BE ATTACHED TO WALL WITH APPROPRIATE ANCHOR SCREWS

- A. 3/8" O.D. SUPPLY INLET
- B. WASTE OUTLET FOR P-TRAP BY OTHERS FOR PROVIDED 1-1/4" O.D. TAILPIECE
- C. ELECTRICAL SERVICE ROUGH (SEE NOTE**)
- D. Ø3/8" HANGER BRACKET PUNCHING, 6 PLACES FOR ANCHORING HARDWARE BY OTHERS
- E. Ø1/4" PUNCHING, 3 PLACES FOR ANCHORING HARDWARE BY OTHERS
- F. 1-1/4" [32] O.D. TAILPIECE FOR P-TRAP BY OTHERS

Electrical Requirements (Chiller & -SO Models):

- Provide Duplex Receptacle on GFCI Protected Circuit
- (Standard) 115VAC, 60Hz, 5A
- (220V Option) 220VAC, 60Hz, 3A

NOTES: Dimensions indicated (*) are for ADA frontal approach installation. Adjust vertical dimension (*) as required to comply with federal, state, and local codes. For Child ADA compliant parallel approach, decrease Bubbler spout height to 30" maximum above finished floor. Provide clear floor space as required. Compliance is subject to the interpretation and requirements of the Local Code Authority.

A172.8-UG SERIES UNIVERSAL BI-LEVEL DRINKING FOUNTAIN - ALTERNATE
(NOTE! Alternate Configuration shown Left Unit Low with Right Unit High)

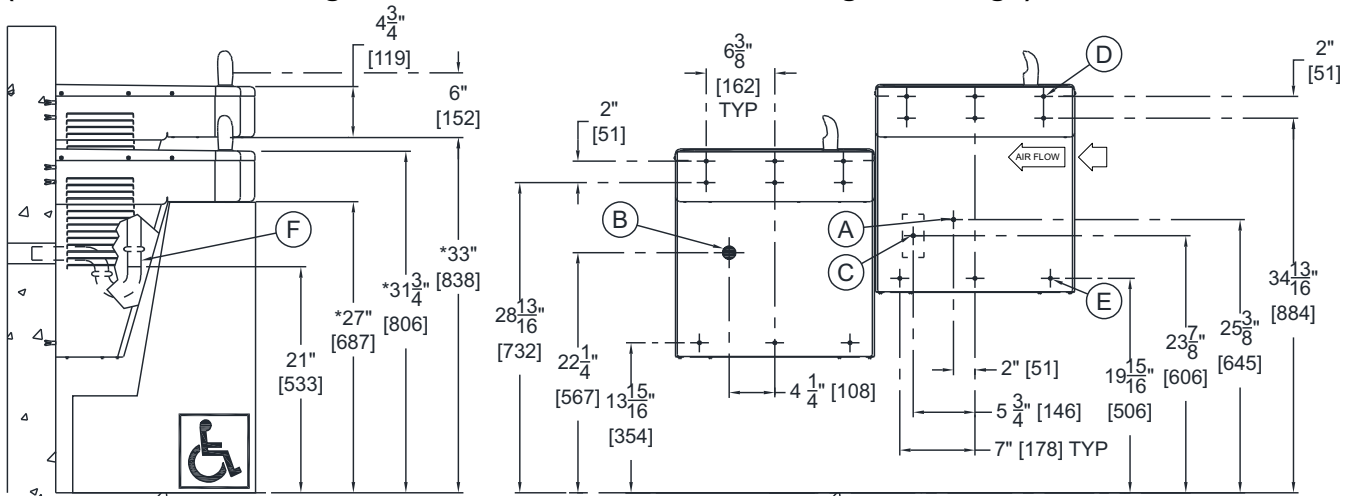

GENERAL NOTES:

1. ALL DIMENSIONS ARE IN INCHES [MM]
2. ALLOW 4 INCHES [102MM] MINIMUM CLEARANCE PER SIDE FOR VENTILATION
- *3. DIMENSIONS SHOWN ARE FOR ADA ADULT HEIGHT. ADJUST VERTICAL DIMENSIONS AS NECESSARY TO COMPLY WITH FEDERAL, STATE & LOCAL CODES
4. STOP VALVE, P-TRAP & ELECTRICAL OUTLET NOT SUPPLIED
5. IMPORTANT: COOLERS MUST BE ATTACHED TO WALL WITH APPROPRIATE ANCHOR SCREWS

- A. 3/8" O.D. SUPPLY INLET
- B. WASTE OUTLET FOR P-TRAP BY OTHERS FOR PROVIDED 1-1/4" O.D. TAILPIECE
- C. ELECTRICAL SERVICE ROUGH (SEE NOTE)
- D. Ø3/8" HANGER BRACKET PUNCHING, 6 PLACES FOR ANCHORING HARDWARE BY OTHERS
- E. Ø1/4" PUNCHING, 3 PLACES FOR ANCHORING HARDWARE BY OTHERS
- F. 1-1/4" [32] O.D. TAILPIECE FOR P-TRAP BY OTHERS

NOTE: REFER TO NOTES ON PREVIOUS PAGE FOR ADDITIONAL DETAILS ON ELECTRICAL ROUGH-IN AND ADA.

IMPORTANT:

1. Waste P-Trap, Water Supply Service Angle Stop Valve and 2" x 4" Electrical Plug-In Receptacle to be supplied by others in accordance with local codes. A P-Trap (by others) must be used for the drain connection.
2. Provide 4" minimum clear space on fixture sides to allow for proper ventilation through cabinet louvers.
3. Water supply is 3/8" Outside Diameter copper tube. Waste is 1-1/4" Outside Diameter.
4. Completely flush supply lines of all foreign debris before connecting to fixture. Water cooler designed to not affect taste, odor, color, or sediment. Optional water filter (WF1 or WF3) is available should any of these problems arise from the water supply.
5. Do **NOT** solder copper tube when inserted into the coupler as damage to the o-ring will result.
6. All burrs must be removed from outside of cut tubes before inserting into coupler or other components.
7. Power supply must be identical in voltage, cycle and phase to that specified on the cooler data plate. Electrical outlet and furnished power cord with plug must be used to supply power to fixture. Do **NOT** wire compressor directly to the power supply.
8. This unit must be grounded per the requirements of applicable electrical codes.
9. **Warranty is voided** if installation is not made following current Murdock Manufacturing installation instructions and if components are assembled to the fixture that is not approved by Murdock Manufacturing.
10. Fixture is to operate within a water pressure range of 20 PSIG (138 kPa) to 105 PSIG (724 kPa). Warranty is void if the unit is allowed to operate outside the range of 20 PSIG (138 kPa) to 105 PSIG (724 kPa). **Consult with UPC and local codes for maximum allowable water pressures.**
11. Due to cold waste water, Murdock Manufacturing recommends that p-trap supplied by installer be insulated to prevent excessive condensation.
12. Per UPC 609.10- *All building water supply systems in which quick acting valves are installed shall be provided with devices to absorb the hammer caused by high pressure resulting from the quick closing of the valve. These pressure-absorbing devices shall be approved mechanical devices. Water pressure-absorbing devices will be installed as close as possible to the quick closing valve.*

STANDARD & ALTERNATE WASTE CONFIGURATION BI-LEVEL DRINKING FOUNTAIN

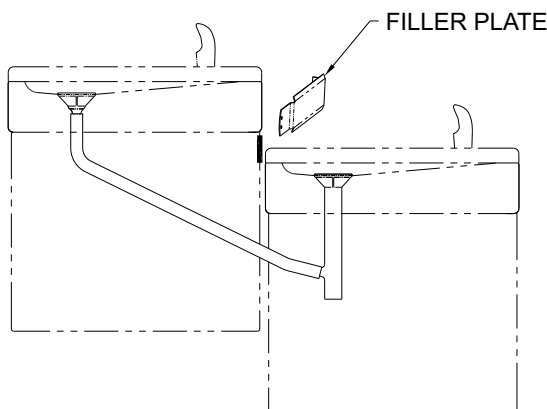

STANDARD WASTE CONFIGURATION

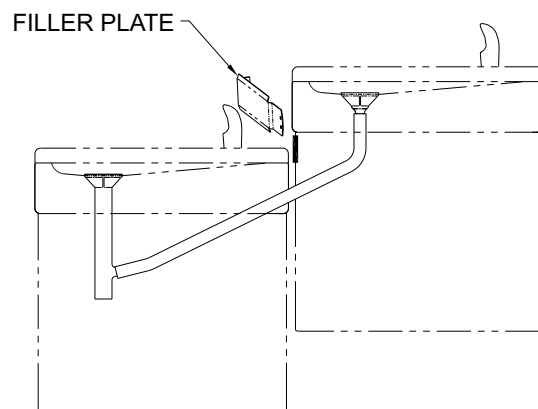

ALTERNATE WASTE CONFIGURATION

PRIOR TO INSTALLATION:

Important: Some options may slightly alter installation. To ensure proper installation, review the Manual thoroughly and verify rough-ins before beginning work. Leave this Manual with the owner or maintenance personnel upon completion of installation.

- Fixture mounting requirements: Industry standard wall construction, adequate to support the fixture and installer-provided Wall Anchors sufficient to secure the fixture.
- Receptacle(s) must be wired to a GFCI protected circuit. Fixture must be earth grounded per NEC (National Electric Code).
- Inspect fixture and all parts for damage.
- To avoid a hazard due to instability, fixture must be installed in accordance with the instructions.

INSTALLATION:

Choose configuration; Remove and reinstall filler plate shown and reverse drain assembly if required for alternate mounting configuration.

1. Mount Hanger Brackets to wall horizontally level as shown in Roughing-In and Dimensional Drawing. **NOTE:** Adjust height of Bracket if Bubbler outlet height is required to vary from that shown /indicated. Hanger Brackets **MUST** be securely anchored to wall with fasteners sufficient to support 3 times the weight of Water Cooler.
NOTE: If wall cannot provide adequate support, order and install Fixture Support Carrier (by others).
2. Remove the Bottom Cover from the Water Cooler and set aside in a safe place. Save the screws in a secure location for re-use in later stages of installation.
3. Hang the Water Coolers on the hanger brackets ensuring the bracket tabs engage **AND** seat in the slots in the back of the Water Coolers. **NOTE:** Hanging of refrigerated unit first is recommended since it is the heavier of the two. Verify Water Coolers are level, left to right **AND** front to back from bottom of unit. **CAUTION:** The Bubbler stream may be adversely affected if units are not square and level. Bottom of units and louvers should be used as reference to verify unit is square and plumb.
4. Anchor the Water Coolers to the wall at the lower mounting points in each back panel. Shim lower mounting points to level unit if necessary.
5. Outlet tube from Evaporator has an in-line tee with a tube going to the refrigerated unit's valve and the "TEE" not connected. Connect the loose Supply Tube from refrigerated unit to the "TEE".
6. Thoroughly flush the 3/8" O.D. supply line and then connect water cooler to water supply angle stop valve (by others) with supplied 3/8" O.D. copper tube.
7. Use supplied flexible hose and clamps to connect waste tailpiece from the upper unit to the waste tailpiece of lower unit and then make up 1-1/4" O.D. p-trap waste connection. Waste p-trap by others.

START UP:

1. **Do not connect electrical power to unit:** With Bottom Cover removed, turn on fixture water supply and check all connections for leaks.
2. Air within the Water Cooler system or the structure supply piping will cause an irregular Bubbler outlet stream until purged out by incoming water. Thoroughly flush and purge air from supply line by depressing the Pushbutton or activating infrared sensor, until steady water stream is achieved.
3. If water flow requires adjustment, insert a slotted narrow blade screwdriver through the hole centered on the pushbutton to the flow regulator. Turning clockwise will increase flow and turning counterclockwise will decrease flow.
4. Recheck all Water and Drain connections with water flowing through system.
5. With power still **NOT** connected, carefully manually rotate cooling fan to insure proper clearance and free fan action.
6. Plug Water Cooler into Electrical Outlet and make sure unit begins to function. **IMPORTANT:** After turning power on to initiate cooler and cool down, immediately purge (chiller) water by operating unit continuously for approx. 1 minute.
7. **IMPORTANT! Thoroughly, inspect all unit connections for water leaks.**
8. Assemble Bottom Cover to Water Cooler with screws furnished.

OUTDOOR INSTALLATION INSTRUCTIONS - A172.8-UG-VR ONLY:

IMPORTANT: Only A172.8-UG-VR Series units without BF11 or BF12 are rated for outdoor use.

- Units installed outdoors presume average conditions and require adequate protection to prevent exposure to extreme hot or cold temperatures which will affect Warranty.
- Best practices include installation beneath an overhang and avoiding direct sunlight.
- Continual ambient temperatures exceeding 80°F (26.67°C) may cause compressor to wear prematurely.
- Units are not freeze resistant.
- Caulk all around the basin where it contacts the wall and where apron contacts the wall as shown, to reduce the possibility of rain water from leaking into the cabinet. **DO NOT CAULK THE REMOVABLE LOWER ACCESS COVER.**

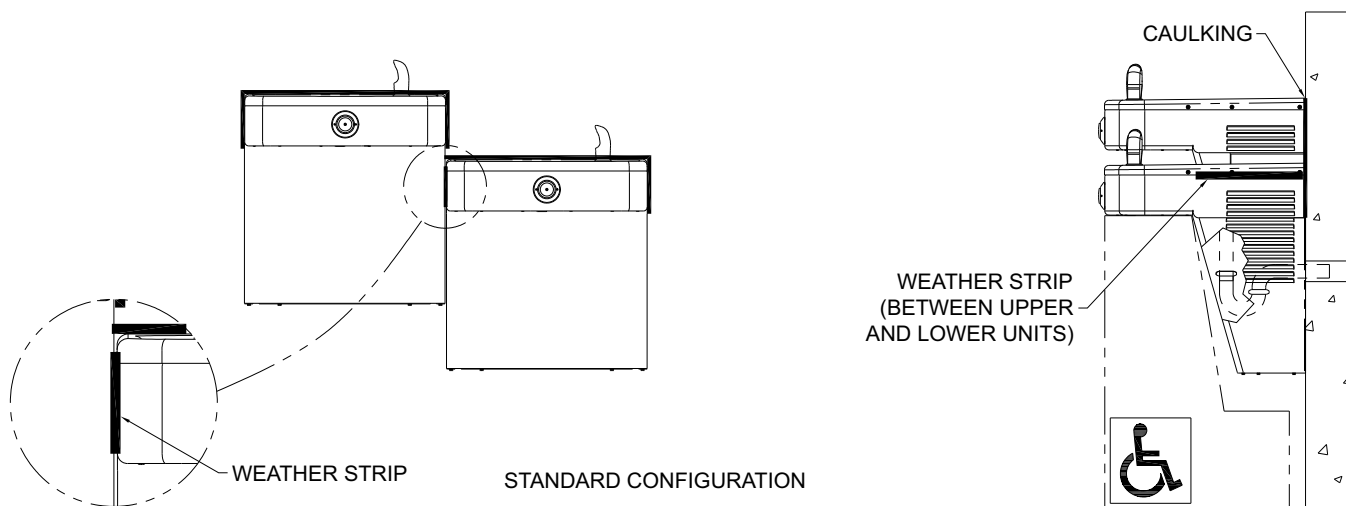

A172.8-UG & A172.8-VR-UG PRESSURIZED BI-LEVEL UNIT PIPING INSTALLATION (WITH -BF OPTION)

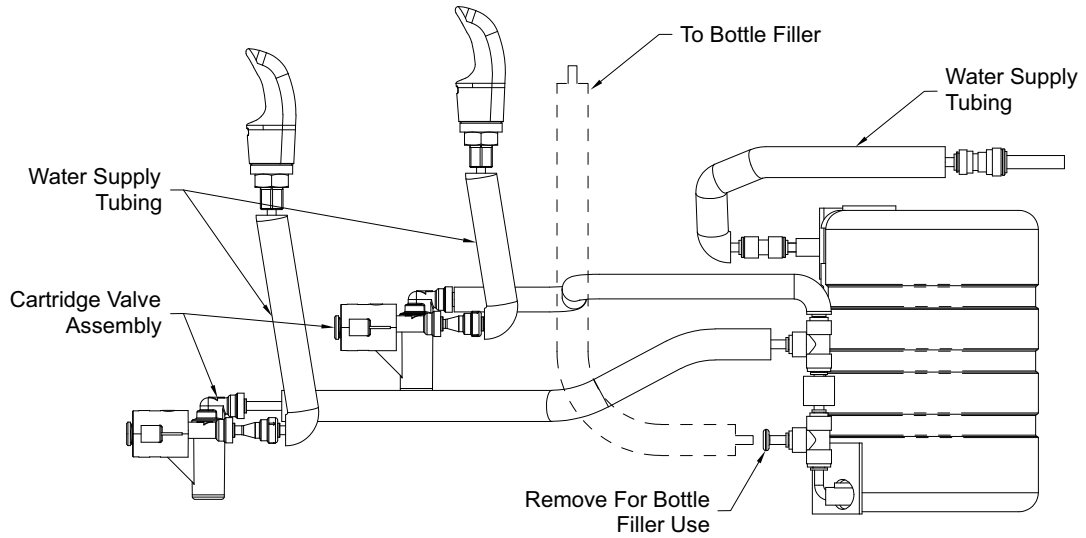

A172.8-UG-SO PRESSURIZED BI-LEVEL UNIT PIPING INSTALLATION

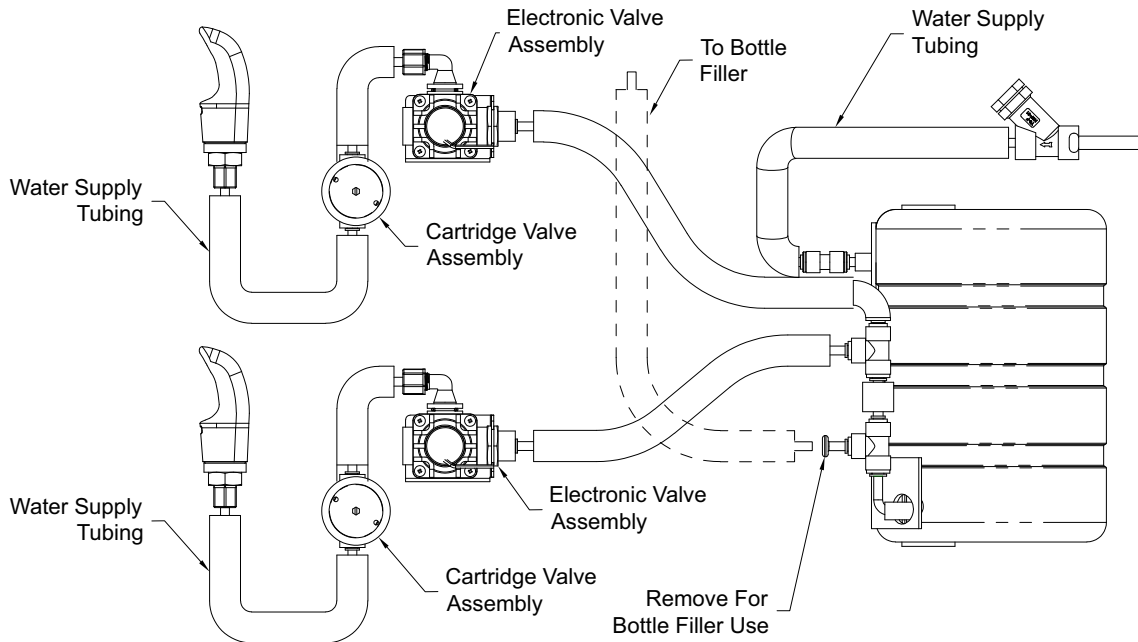

PUSH-IN FITTING INSTALLATION

NOTE: FITTINGS AND TUBE SHOULD BE KEPT CLEAN, BAGGED AND UNDAMAGED PRIOR TO INSTALLATION.

TO CUT TUBE:

Cut to fit length of 1/4" PE tubing and remove any burrs or sharp edges. Ensure that the outside diameter is free from score marks. Tube ends should be square.

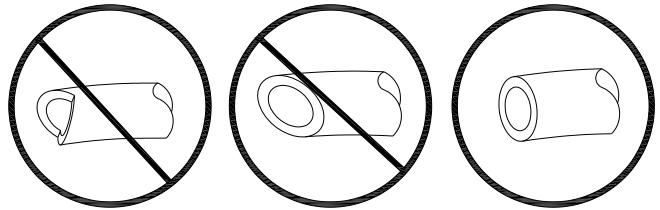

INSERTING THE TUBE:

1. Firmly and fully insert the tubing end into the push-in fitting up to the tube stop located approximately 1/2" deep.

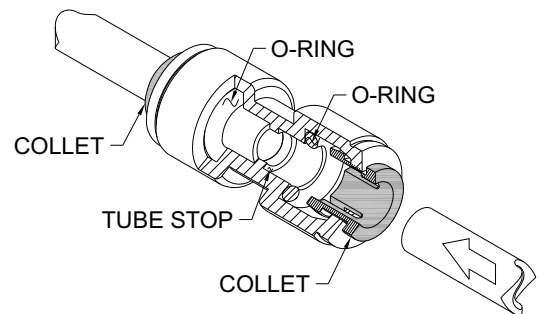

2. Pull on the fitted tubing to ensure it is secure. Tube should not come free from the fitting. Water test the connection assembly prior to leaving the site to ensure there are no leaks.

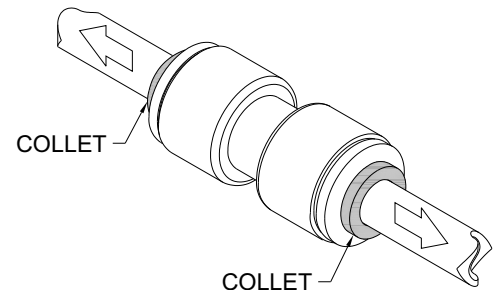

DISCONNECTING THE TUBE:

To disconnect the tube from the fitting ensure that the water line is depressurized. Push collet square towards the push-in fitting body and hold. While holding the collet in, pull on the PE tubing to remove from the push-in fitting.

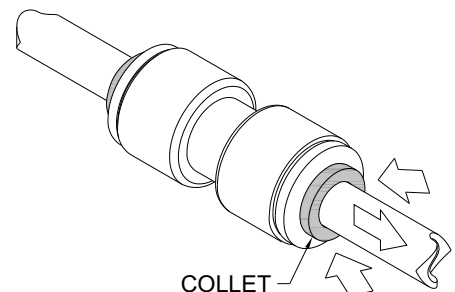

OPTIONAL WATER FILTER INSTALLATION:

-WF1EZ FILTER (Detail A):

REFER TO INSTALLATION DETAILS PROVIDED WITH -WF1EZ (REFERENCE INSTALLATION DRAWING 7020-009-001)

-WF1 FILTER CARTRIDGE INSTALLATION:

WATER FILTER HAS 1500 GALLON CAPACITY, CARTRIDGE WILL REQUIRE REPLACEMENT AFTER 50 HOURS OF ACTUAL OPERATIONAL USAGE. FREQUENCY OF FIXTURE OPERATION WILL DETERMINE TIME FRAME FOR CARTRIDGE REPLACEMENT. (-SO, -SOC, -FG MODELS)

-WF3 FILTER CARTRIDGE INSTALLATION:

WATER FILTER HAS 3000 GALLON CAPACITY, CARTRIDGE WILL REQUIRE REPLACEMENT AFTER 100 HOURS OF ACTUAL OPERATIONAL USAGE. FREQUENCY OF FIXTURE OPERATION WILL DETERMINE TIME FRAME FOR CARTRIDGE REPLACEMENT.

IMPORTANT:

FLUSH 3-5 GALLONS OF WATER THROUGH THE FILTER BEFORE INITIAL USE!

(Bubbler run time for approximately 10-15 minutes, Bottle Filler run time for approximately 3-5 minutes.)



Detail A

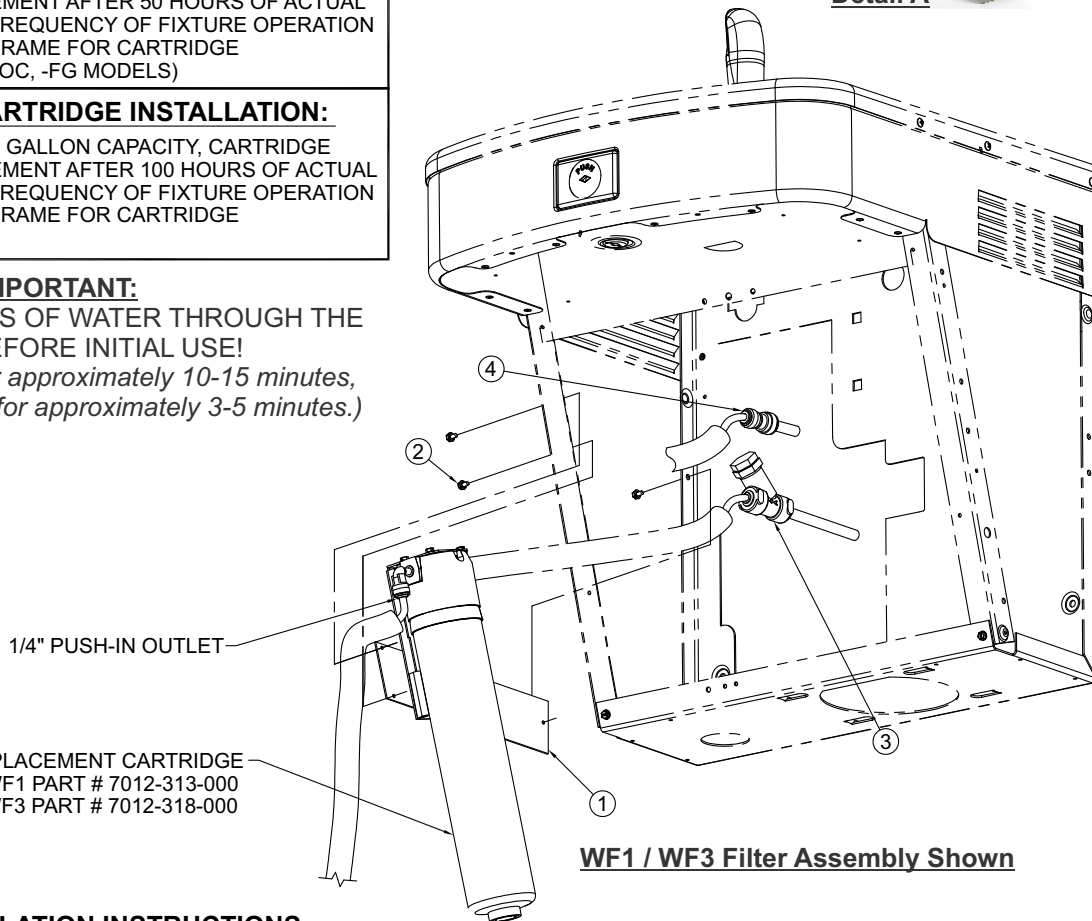

WF1 / WF3 Filter Assembly Shown

REPLACEMENT CARTRIDGE
-RWF1 PART # 7012-313-000
-RWF3 PART # 7012-318-000

-WF1, -WF3 INSTALLATION INSTRUCTIONS:

- A- REMOVE THE BOTTOM HOUSING AND TURN OFF UNIT WATER SUPPLY. IF UNIT IS A REFRIGERATED MODEL, DISCONNECT FROM THE POWER SUPPLY.
- B- PLACE FILTER/BRAKET ASSEMBLY ① ON INSIDE OF UNIT FRAME AND ALIGN HOLES IN THE BRACKET WITH THE HOLES OF THE UNIT FRAME.
- C- USE THE SCREWS ② PROVIDED TO PASS THRU THE FRAME CLEARANCE HOLES AND SCREW INTO THE BRACKET HOLES.
- D- FOLLOW PE TUBE FROM "Y" STRAINER ③ OR PUSH-IN UNION ④ TO WHERE IT CONNECTS TO THE EVAPORATOR. DISCONNECT TUBE FROM EVAPORATOR, CONNECT TO FILTER INLET PUSH-IN CONNECTION.
- E- CONNECT NEW PE TUBE PROVIDED WITH FILTER TO EVAPORATOR PUSH-IN INLET, WHERE TUBE WAS REMOVED.

- F- TURN ON WATER. CHECK FOR LEAKS.
- G- IMPORTANT: FLUSH 5 GALLONS OF WATER THRU THE FILTER BEFORE ALLOWING FIXTURE USE.
- H- IF REFRIGERATED UNIT, TURN ON POWER SUPPLY AND CHECK UNIT FOR PROPER OPERATION.
- I- RE-INSTALL BOTTOM HOUSING.

NOTES:

- 1- TO DISCONNECT THE TUBE FROM THE PUSH-IN FITTING TUBE HOLD DOWN GRIPPER AND PULL TUBE OUT SLOWLY.
- 2- TO CONNECT PUSH-IN FITTINGS, PUSH TUBE IN ALL THE WAY TO MAKE A GOOD CONNECTION. CARTRIDGE REPLACEMENT.

TROUBLESHOOTING:

IMPORTANT: BEFORE MAKING ANY OF THE REPAIRS LISTED, MAKE SURE THE WATER COOLER IS DISCONNECTED FROM THE ELECTRICAL SUPPLY AND THE WATER SUPPLY VALVE IS SHUT OFF.
IMPORTANT : ASSUREZ-VOUS QUE LA FONTAINE D'EAU POTABLE RÉFRIGÉRÉE SOIT DÉBRANCHÉE DE LA PRISE DE COURANT MURALE ET QUE LE ROBINET D'ALIMENTATION D'EAU SOIT FERMÉ AVANT D'EFFECTUER LES RÉPARATIONS NÉCESSAIRES.

1. Adjustments

- a. **Cartridge** – The water flow can be adjusted using a slotted narrow blade Screwdriver and turning clockwise to increase flow and counterclockwise to decrease flow.
- b. **Bubbler Stream** – Bubbler can be rotated slightly to direct the stream backwards or forwards. Adjust the stream to minimize splashing. Splashing may occur from Bubbler stream if the unit is not level. Shim lower mounting points, if necessary, to level Water Cooler.
- c. **Cold Water Thermostat** – **IMPORTANT:** Thermostat is Factory pre-set. Thermostat settings should never be field adjusted since damage to fixture may occur, voiding product Warranty.

2. Compressor Does Not Run

- a. Check the electrical receptacle for power and correct voltage. The incoming voltage must be within 10% of the rated voltage on the serial nameplate.
- b. The cold thermostat is accessible by removing the bottom access cover. If the cold thermostat capillary bulb loses its charge or becomes kinked it will fail in the open position causing a disruption of power to the compressor. Unplug the water cooler and using an ohm meter check for continuity across the two electrical terminals on the thermostat. Install a new thermostat if there is no continuity.
- c. Check for loose wires within the compressor box. The incoming power leads must be connected to the overload and relay.
- d. If all components check positive for continuity then test the wiring harness plug for continuity to see if there is a broken wire within the wiring harness insulation.

3. Compressor Runs – Water Is Warm

- a. The most common cause for a water cooler to run without producing cold water is a loss of refrigerant. The water cooler must be taken to a certified refrigerant technician for repairs.
- b. Make sure the condenser fan motor is operative. The fan blade must turn freely to help remove the heat of compression.
- c. An incorrect refrigerant charge, restriction or defective compressor (not pumping) will also cause the compressor to run without producing cold water. All these signs indicate a problem within the refrigeration system and the water cooler must be checked by an authorized service company.

4. Compressor Cycling On Overload Protector

- a. A dirty condenser or a blocked fan will cause a high head pressure and frequent cycling of the overload protector.
- b. Check the incoming voltage to make sure it is within 10% of the serial nameplate rating.
- c. A restriction or moisture in the system will also cause intermittent cycling. A certified refrigeration mechanic should be contacted in this situation.
- d. Change the overload or relay if defective.

5. Noisy Operation

- a. Check to make sure the fan blade is rotating freely.
- b. Make sure the water cooler is correctly mounted to the wall. Absence of the two lower mounting bolts may cause excess noise and vibration.
- c. Check the compressor mounting to make sure the pins and clips are not rattling. If the compressor appears to be noisy internally, it must be replaced.

TROUBLESHOOTING (CONTINUED):

6. Restricted Or No Water Flow

- a. Ensure water supply service stop valve is fully open.
- b. Verify minimum 20 psig supply line flow pressure.
- c. Check for twists or kinks in bubbler tubing.
- d. Check the water inlet strainer. Sediment from the main supply can get trapped in the screen along with installation materials such as pipe dope and flux. The screen should be cleaned and checked on a regular basis and replace if needed.
NOTE: STRAINER SCREEN MUST BE IN PLACE FOR WATER TO FLOW.
- e. The cartridge valve located in the water control assembly or bubbler can also become clogged with foreign material. The cartridge valve can only be replaced and not repaired.
- f. Check flow adjustment. See start up note #3.
- g. The water cooler may develop a freezing condition in which the water will become frozen inside the evaporator coil. This indicates a refrigeration problem or thermostat failure. Disconnect the electrical power and have the unit checked by a qualified technician.

For Sensor Operated Coolers

- h. If light within sensor does NOT flash when the users hands are within range:
 - i: Verify power supply to transformer
 - ii Replace defective 9VDC transformer.
 - iii: Transformer polarity crossed. Replace Transformer. (Sensor may be damaged and need replacing)
 - iv: Sensor in "Security Mode" after 90 seconds of constant detection. Remove source of detection and wait 30 seconds before checking.
 - v: Sensor range is too short or too long. See SENSOR RANGE ADJUSTMENT section.
 - vi: Sensor is picking up a highly reflective surface. Eliminate cause of reflection and wait.

7. Water Drip Or Will Not Shut Off:

- a. Remove Pushbutton Adjust flow regulator to the highest setting using a flat head screwdriver and turning clockwise. Check if water drip continues, if it is no longer dripping turn screwdriver counter-clockwise until you have desired flow rate. Assure that retaining nut is tighten to valve assembly, 25 in-lb torque is required. If issue still continues after adjusting flow and tightening retainer nut, replacement of the flow regulator cartridge will be required.

CLEANING & MAINTENANCE GUIDE:

1. Motors have lifetime lubrication and do not require scheduled maintenance.
2. Excess dirt or poor ventilation will cause the compress` more frequently.
3. Periodically remove access panels and clean out in-line strainer.
4. Do NOT use harsh chemicals, abrasive or petroleum based cleaners. Use of these will void the Murdock warranty.
5. Exterior panels can be cleaned using mild household detergents or warm, soapy water. Extra care must be used cleaning chrome plated items and mirror finished stainless steel. They can scratch easily and should only be cleaned using a clean, soft cloth and mild soap with water or a mild glass cleaner.

FOR A171.8-UG-SO ONLY

SENSOR RANGE ADJUSTMENT

- A. Disconnect sensor from power supply.

- B. Create a short circuit between the positive and negative connections on the sensor for five seconds. **WARNING: Do NOT** create a short circuit on the power supply or while the sensor is connected to the power supply.

- C. Reconnect the sensor to the power supply.

- D. Within 5 seconds of making the connection to the power supply, place and hold hand 2" to 4" in front of sensor.

- E. Once red light within sensor begins flashing quickly, move hand to preferred activation distance, move hand to preferred activation distance and hold there until light stops flashing.

Check sensor activation distance. If unsatisfactory, repeats steps A through E.

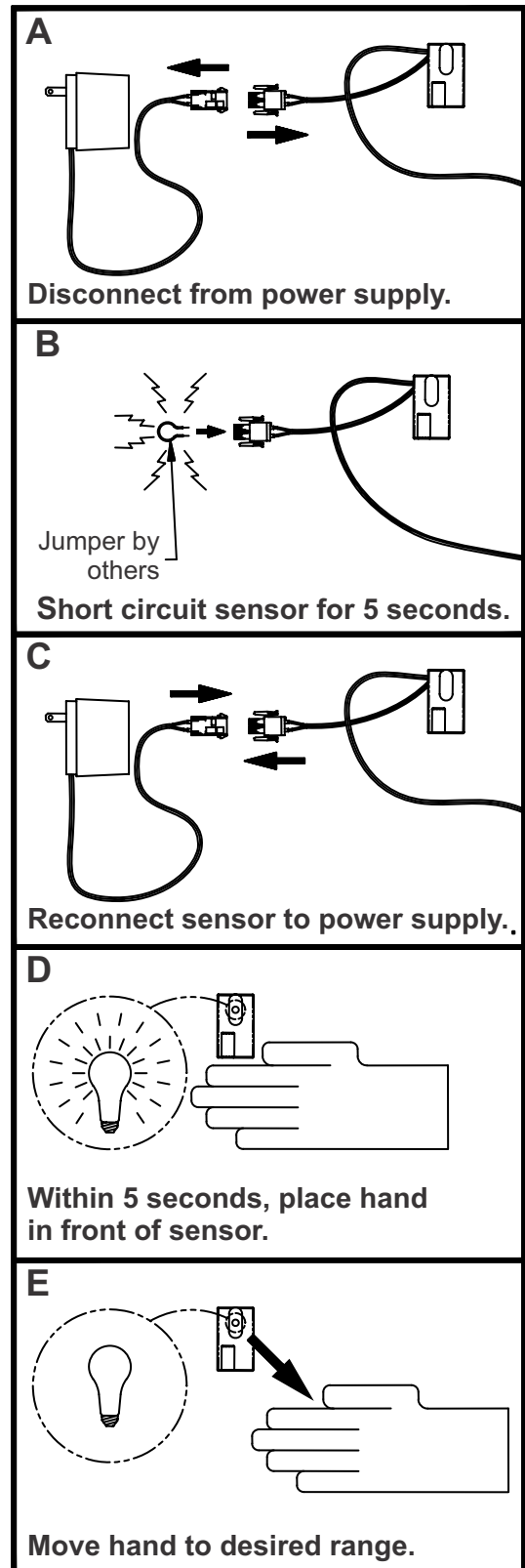

CARTRIDGE REPLACEMENT/ STRAINER MAINTENANCE

Note: Use the universal maintenance tool to perform the following:

1. Strainer plug must be removed before cartridge replacement and strainer maintenance (no need to turn the water off at the angle stop). Some residual water will drain during plug removal.
2. Clean strainer as needed using clean water.
3. Cartridge replacement - insert diamond end of the universal tool into push button, rotate 90 degrees and pull firmly to remove the button. Remove cartridge retaining nut . Remove and replace cartridge. When replacing cartridge be sure to align the inlet and outlet ports on the cartridge with the ports in the valve body.

• **NOTE: STRAINER SCREEN MUST BE IN PLACE FOR WATER TO FLOW.**

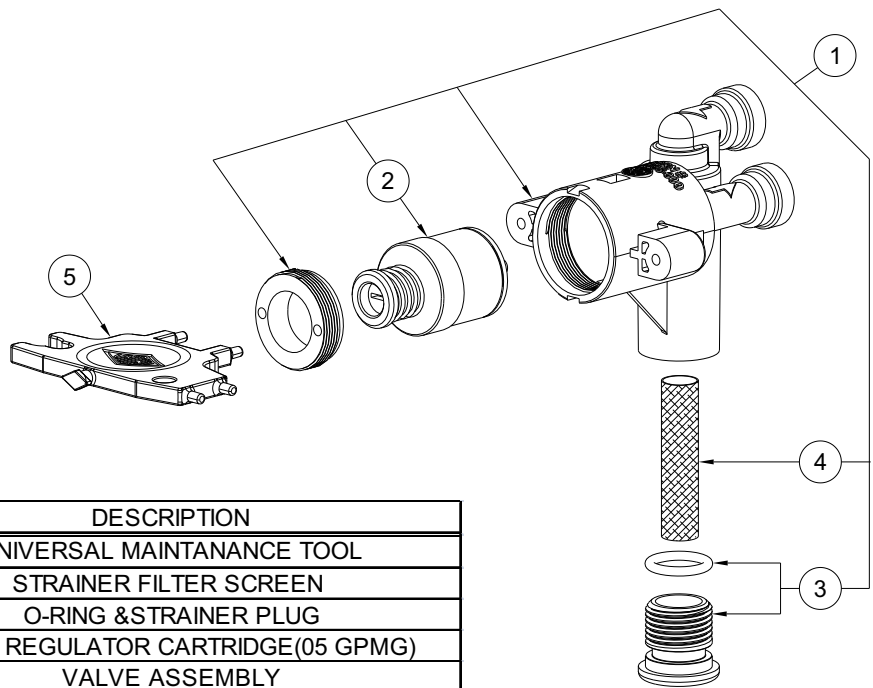

ITEM	PART NUMBER	DESCRIPTION
5	7003-830-000	UNIVERSAL MAINTANANCE TOOL
4	7003-864-000	STRAINER FILTER SCREEN
3	7003-097-001	O-RING & STRAINER PLUG
2	7000-060-000	FLOW REGULATOR CARTRIDGE(05 GPMG)
1	7003-095-001	VALVE ASSEMBLY

-UG-VR VANDAL RESISTANT CARTRIDGE REPLACEMENT/ STRAINER MAINTENANCE

Note: Use the **-VR** maintenance tool to perform the following:

1. Strainer plug (4) **must** be removed before cartridge replacement and strainer maintenance (no need to turn the water off at the angle stop). Some residual water will drain during plug removal.
2. Clean strainer (4) as needed using clean water.
3. Cartridge replacement - Rotate and remove **-VR** pushbutton escutcheon (6) to release pushbutton (7) and springs (8) (9) to access cartridge.
4. Remove cartridge retaining nut (10). Remove and replace cartridge (2). When replacing cartridge be sure to align the inlet and outlet ports on the cartridge with the ports in the valve body.
5. Install item (10) using maintenance tool (5) (Be careful not to over tighten)
6. Install button assembly items (6) (7) (8) (9) using maintenance tool (5). Insure springs are installed in button correctly.
7. Reinstall strainer (4) and plug (3) using maintenance tool (5).

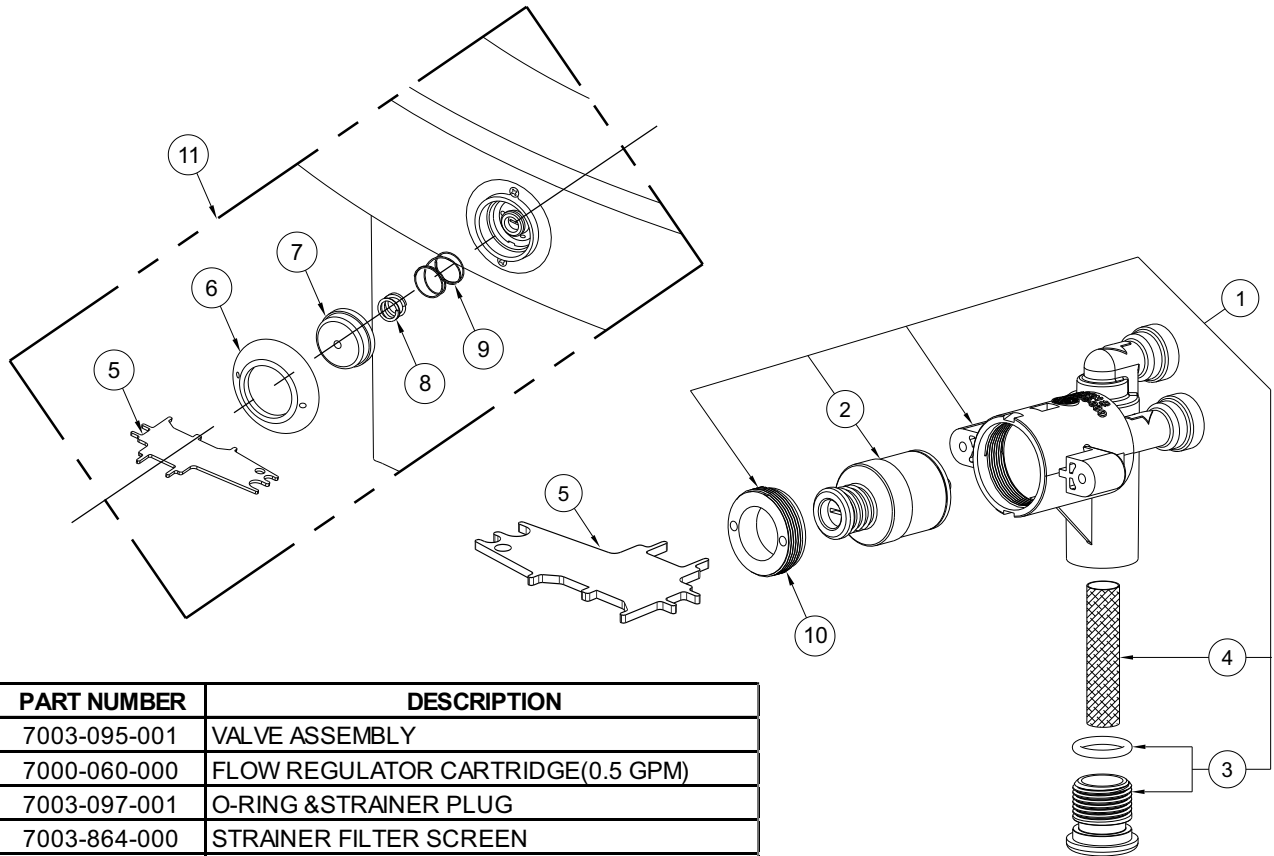

ITEM	PART NUMBER	DESCRIPTION
1	7003-095-001	VALVE ASSEMBLY
2	7000-060-000	FLOW REGULATOR CARTRIDGE(0.5 GPM)
3	7003-097-001	O-RING & STRAINER PLUG
4	7003-864-000	STRAINER FILTER SCREEN
5	7003-194-199	(-VR) MAINTENANCE TOOL
6	7003-197-199	(-VR) PUSHBUTTON ESCUTCHEON, CHROME
7	7003-196-199	(-VR) PUSHBUTTON, CHROME
8	7003-195-000	(-VR) PUSHBUTTON OVERTRAVEL SPRING
9	7003-193-000	(-VR) PUSHBUTTON RETURN SPRING
10	7000-052-000	RETAINING NUT
11	7003-099-001	(-VR) PUSHBUTTON ASSY - ITEMS #5 THRU #9

NOTE: STRAINER FILTER SCREEN MUST BE IN PLACE FOR WATER TO FLOW.

-SO SENSOR OPERATED CARTRIDGE VALVE PARTS BREAKDOWN

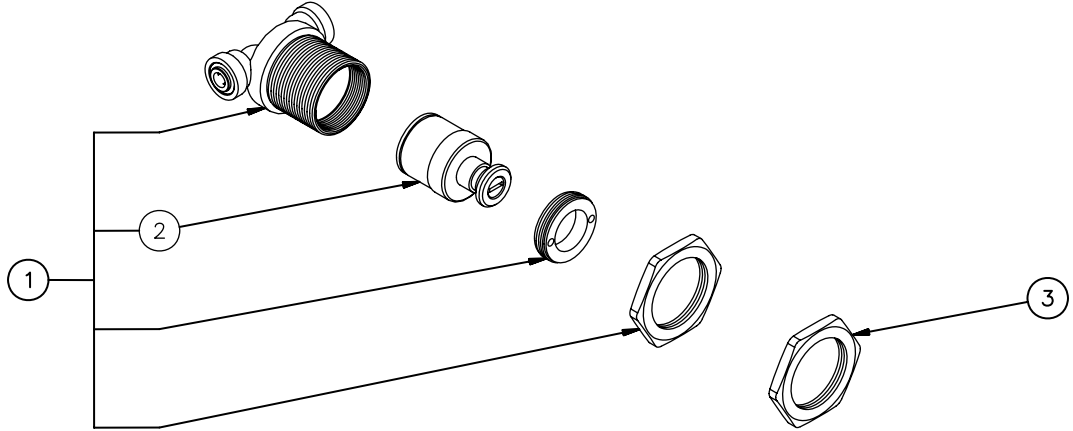

ITEM #	PART NUMBER	DESCRIPTION
1	7000-050-001	Valve Cartridge Assembly
2	7000-060-000	Valve Cartridge
3	7000-053-199	Jam Nut

-SO SENSOR OPERATED WIRING DIAGRAM WITH -BF12

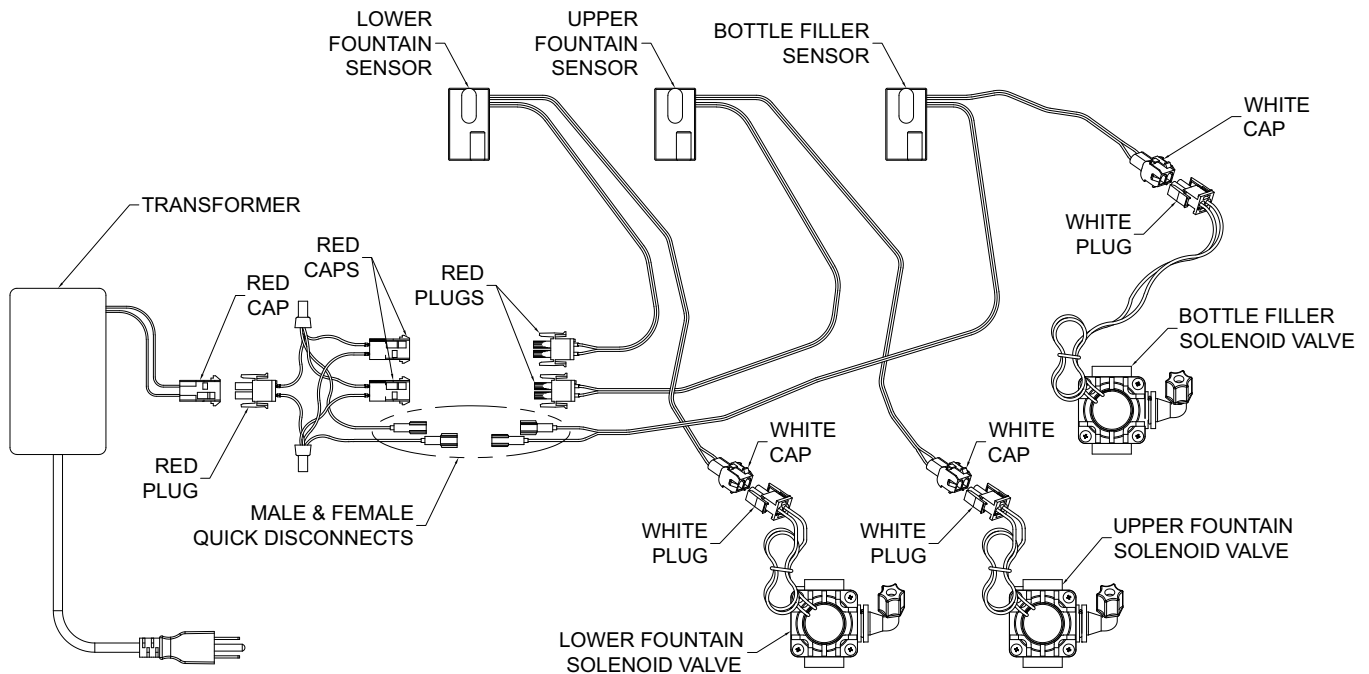

A172.8-UG WATER COOLER PARTS BREAKDOWN DRAWING:

NOTE: See following page for table of part numbers corresponding to drawing below.

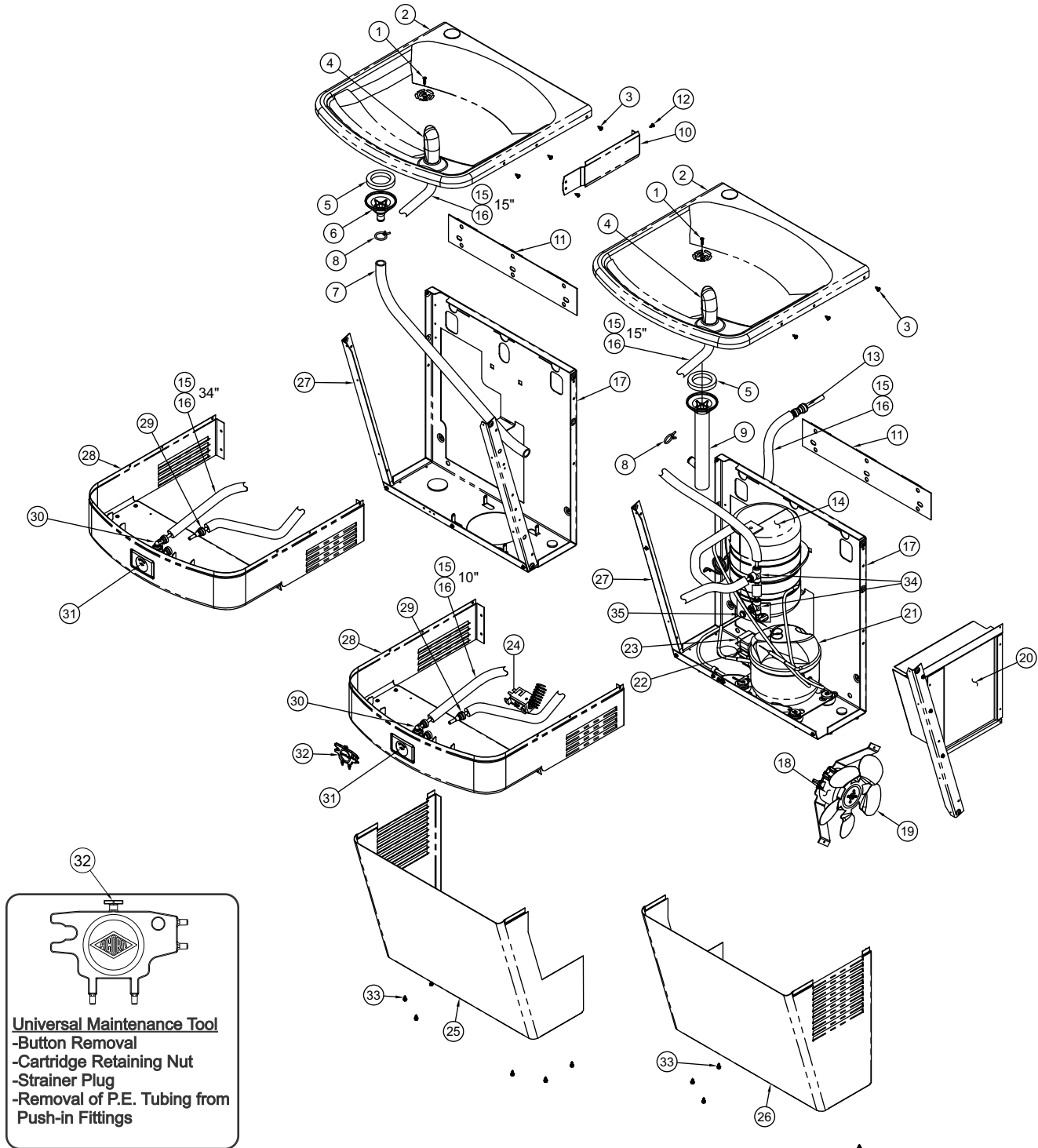

Standard A172-UG series refrigerated ADA cooler shown. All 1/4" O.D. Plastic tubing (15) must be insulated with (16) foam insulation.

A172.8-UG COOLER PARTS BREAKDOWN TABLE

NOTE: See previous page for fixture drawing corresponding to table of parts below.

ITEM#	PART NUMBER	DESCRIPTION
1	0124-008-000	#8 x 3/4" LG TORX FLAT HD SELF TAPPING SCREW
2	7003-161-001	BASIN TOP w/ HOLE AND PLUG FOR -BF11 & BF12
3	0124-036-000	#8 x 1/2" LG TORX RD HEAD MACHINE SCREW
4	7000-012-001	STAINLESS STEEL BUBBLER ASSEMBLY
	7000-099-002	LOW FLOW FLEXIBLE BUBBLER ASSEMBLY
5	7000-006-000	FLAT DRAIN GASKET
6	7003-182-000	DRAIN TAIL PIECE (SHORT)
7	7003-183-199	DRAIN HOSE
8	7003-184-000	7/8" SPRING HOSE CLAMP
9	7003-181-000	DRAIN TAIL PIECE (LONG)
10	7003-956-020	FILLER PLATE - GRAY
	7003-825-199	FILLER PLATE - STAINLESS STEEL
11	7003-950-199	HANGER BRACKET
12	0124-050-000	#8 x 3/8" LG PHILLIPS PAN HEAD SCREW
13	1895-123-000	1/4" OD x 3/8" OD PUSH-IN CONNECTION
14	7003-125-001	EVAPORATOR ASSEMBLY
15	2169-000-000	1/4" OD TUBING
16	7012-055-000	TUBE INSLULATION
17	7003-923-003	VANDAL RESISTANT BACK PANEL
	7003-900-199	BACK PANEL
18	7003-302-000	FAN MOTOR
	7012-062-001	FAN MOTOR - 220V
19	7003-350-000	FAN BLADE
20	7003-201-000	CONDENSER
21	7012-801-000	COMPRESSOR
	7012-030-001	COMPRESSOR - 220V
22	7012-802-000	START RELAY
	7012-031-000	START RELAY - 220V
23	7012-803-000	START CAPACITOR
	7012-032-000	START CAPACITOR - 220V
24	7003-250-000	COLD CONTROL
25	7003-954-020	LEFT CABINET - GRAY
	7003-823-299	LEFT CABINET - STAINLESS STEEL
26	7003-955-020	RIGHT CABINET - GRAY
	7003-824-299	RIGHT CABINET - STAINLESS STEEL
27	7003-007-199	SUPPORT STRUT
28	7003-953-002	APRON ASSEMBLY - GRAY
	7003-826-002	APRON ASSEMBLY - STAINLESS STEEL
29	7003-093-001	FLOW RESTRICTOR - LOW-FLOW BUBBLER ONLY
30	7003-095-001	VALVE ASSEMBLY
31	7003-099-000	PUSHBUTTON
32	7003-830-000	MAINTENANCE TOOL
33	0124-031-000	#8 x 3/8" LNG SLOTTED HEX WASHER HD SCREW
34	1895-710-000	1/4" O.D. TUBE, TEE
35	1895-715-000	1/4" PLUG

Repairs must be made with Murdock Manufacturing parts only. Please order through your local representative or distributor.

-UG-VR VANDAL RESISTANT WATER COOLER PARTS BREAKDOWN DRAWING:

NOTE: See following page 17 for table of part numbers corresponding to drawing below.

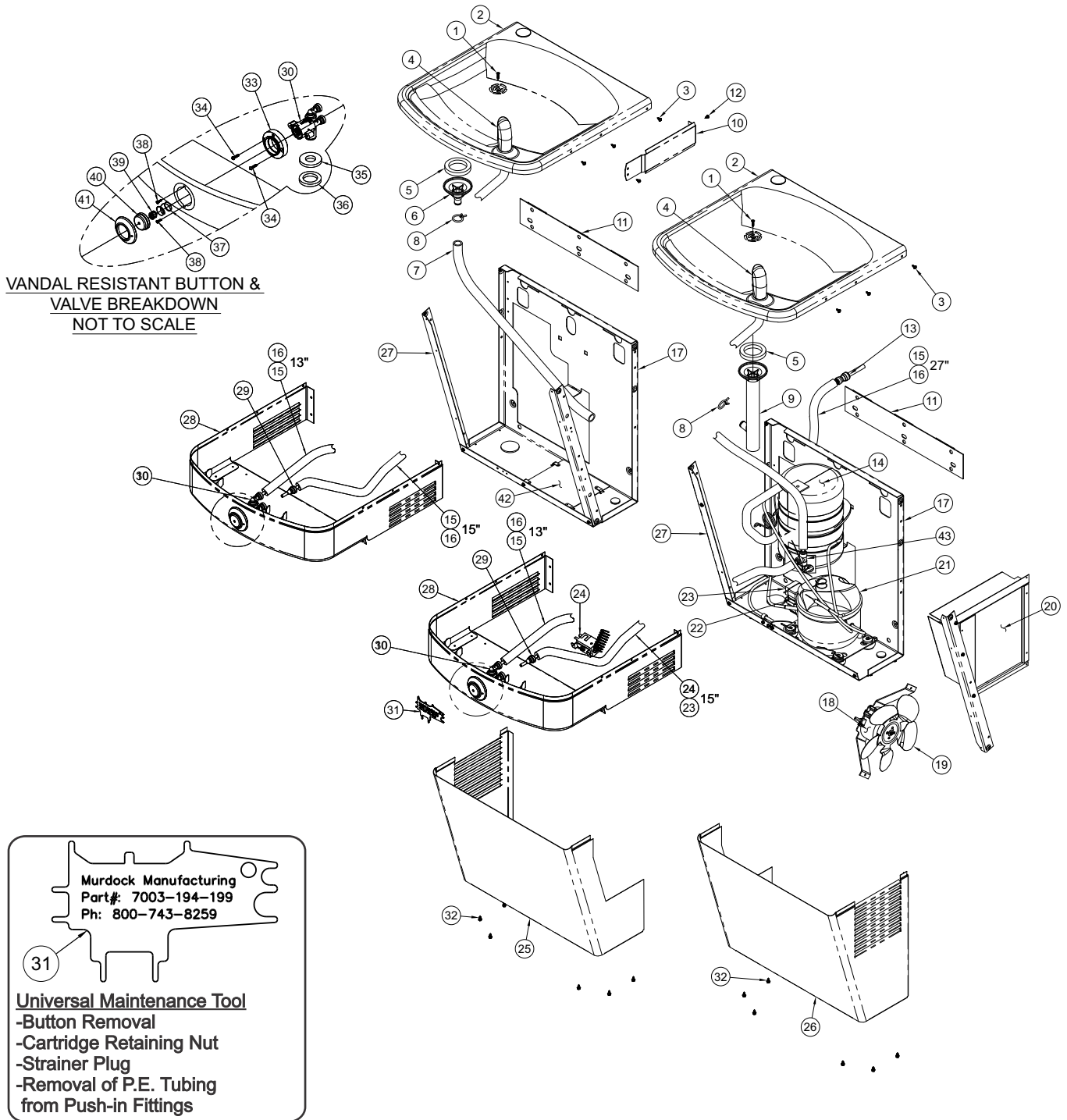

Repairs must be made with Murdock Manufacturing parts only. Please order through your local representative or distributor.

-UG-VR VANDAL RESISTANT COOLER PARTS BREAKDOWN TABLE

NOTE: See previous page for fixture drawing corresponding to table of parts below.

ITEM #	PART NUMBER	DESCRIPTION
1	0124-008-000	#8 x 3/4" LG TORX FLAT HD SELF TAPPING SCREW
2	7003-161-001	BASIN TOP w/ HOLE AND PLUG FOR -BF11 & BF12
3	0124-036-000	#8 x 1/2" LG TORX RD HEAD MACHINE SCREW
4	7000-012-001	STAINLESS STEEL BUBBLER ASSEMBLY
	7000-099-002	LOW FLOW FLEXIBLE BUBBLER ASSEMBLY
5	7000-006-000	FLAT DRAIN GASKET
6	7003-182-000	DRAIN TAIL PIECE (SHORT)
7	7003-183-199	DRAIN HOSE
8	7003-184-000	7/8" SPRING HOSE CLAMP
9	7003-181-000	DRAIN TAIL PIECE (LONG)
10	7003-956-020	FILLER PLATE - GRAY
	7003-825-199	FILLER PLATE - STAINLESS STEEL
11	7003-950-199	HANGER BRACKET
12	0124-050-000	#8 x 3/8" LG PHILLIPS PAN HEAD SCREW
13	1895-123-000	1/4" OD x 3/8" OD PUSH-IN CONNECTION
14	7003-125-001	EVAPORATOR ASSEMBLY
15	2169-000-000	1/4" OD TUBING
16	7012-055-000	TUBE INSULATION
17	7003-923-003	VANDAL RESISTANT BACK PANEL
	7003-900-199	BACK PANEL
18	7003-302-000	FAN MOTOR
	7012-062-001	FAN MOTOR - 220V
19	7003-350-000	FAN BLADE
20	7003-201-000	CONDENSER
21	7012-801-000	COMPRESSOR
	7012-030-001	COMPRESSOR - 220V
22	7012-802-000	START RELAY
	7012-031-000	START RELAY - 220V
23	7012-803-000	START CAPACITOR
	7012-032-000	START CAPACITOR - 220V
24	7003-250-000	COLD CONTROL
25	7003-954-020	LEFT CABINET - GRAY
	7003-823-299	LEFT CABINET - STAINLESS STEEL
26	7003-955-020	RIGHT CABINET - GRAY
	7003-824-299	RIGHT CABINET - STAINLESS STEEL
27	7003-007-199	SUPPORT STRUT
28	7003-952-021	APRON ASSEMBLY - GRAY
	7003-211-004	APRON ASSEMBLY - STAINLESS STEEL
29	7003-093-001	FLOW RESTRICTOR - LOW-FLOW BUBBLER ONLY
30	7003-095-001	VALVE ASSEMBLY
31	7003-194-199	(-VR) MAINTENANCE TOOL
32	0124-031-000	#8 x 3/8" LNG SLOTTED HEX WASHER HD SCREW
33	7003-198-199	(-VR) PUSHBUTTON MOUNTING SLEEVE
34	0124-055-000	#8x3/4 PHILLIPS ROUND HEAD SS SM SCREW
35	7003-199-000	AUTO-STOP CONDENSATION GASKET, UPPER
36	7003-200-000	AUTO-STOP CONDENSATION GASKET, LOWER
37	7003-193-000	(-VR) PUSHBUTTON RETURN SPRING
38	0161-062-000	#6-32 x 1/2" S/S PHIL FLAT HD SCREW
39	7003-195-000	(-VR) PUSHBUTTON OVERTRAVEL SPRING
40	7003-196-199	(-VR) PUSHBUTTON, CHROME
41	7003-197-199	(-VR) PUSHBUTTON ESCUTCHEON, CHROME
42	7003-048-199	COVER PLATE, -VR EMPTY UNIT
43	1895-710-000	1/4" O.D. TUBE, TEE

-SO SENSOR OPERATED WATER COOLER PARTS BREAKDOWN DRAWING:

NOTE: See following page for table of part numbers corresponding to drawing below.

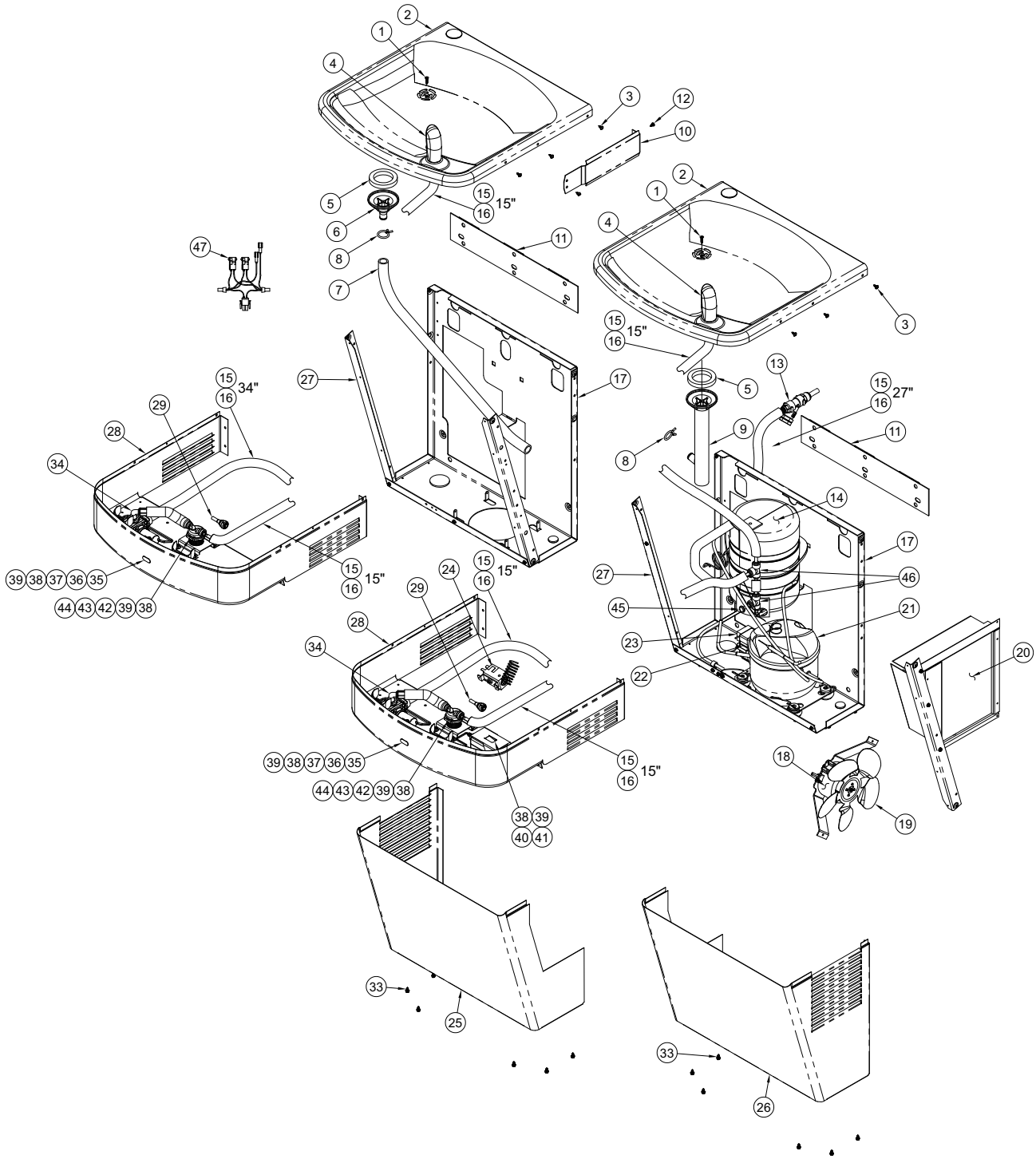

Repairs must be made with Murdock Manufacturing parts only. Please order through your local representative or distributor.

-SO COOLER PARTS BREAKDOWN TABLE

NOTE: See previous page for fixture drawing corresponding to table of parts below.

ITEM#	PART NUMBER	DESCRIPTION
1	0124-008-000	#8 x 3/4" LG TORX FLAT HD SELF TAPPING SCREW
2	7003-161-001	BASIN TOP WITH HOLE FOR BF11/12
3	0124-036-000	#8 x 3/4" LONG TORX SHEET METAL SCREW
4	7000-099-002	LOW-FLOW FLEXIBLE BUBBLER ASSEMBLY
	7000-012-001	STAINLESS STEEL BUBBLER ASSEMBLY
5	7000-006-000	FLAT DRAIN GASKET
6	7003-182-000	DRAIN TAIL PIECE (SHORT)
7	7003-183-199	DRAIN HOSE
8	7003-184-000	7/8" SPRING HOSE CLAMP
9	7003-181-000	DRAIN TAIL PIECE (LONG)
10	7003-956-020	FILLER PLATE - GRAY
	7003-825-199	FILLER PLATE - STAINLESS STEEL
11	7003-950-199	HANGER BRACKET
12	0124-050-000	#8 x 3/8" LONG PHILLIPS PAN HEAD SCREW
13	1895-123-000	1/4" OD x 3/8" OD PUSH-IN CONNECTION
14	7003-125-001	EVAPORATOR ASSEMBLY
15	2169-000-000	1/4" OD TUBING
16	7012-055-000	TUBE INSULATION
17	7003-900-199	BACK PANEL
18	7003-302-000	FAN MOTOR
	7012-062-001	FAN MOTOR - 220V
19	7003-350-000	FAN BLADE
20	7003-201-000	CONDENSER
21	7012-801-000	COMPRESSOR
	7012-030-001	COMPRESSOR - 220V
22	7012-802-000	START RELAY
	7012-031-000	START RELAY - 220V
23	7012-803-000	START CAPACITOR
	7012-032-000	START CAPACITOR - 220V
24	7003-250-000	COLD CONTROL
25	7003-954-020	LEFT CABINET - GRAY
	7003-823-299	LEFT CABINET - STAINLESS STEEL
26	7003-955-020	RIGHT CABINET - GRAY
	7003-824-299	RIGHT CABINET - STAINLESS STEEL
27	7003-007-199	SUPPORT STRUT
28	7003-953-020	APRON ASSEMBLY - GRAY
	7003-826-001	APRON ASSEMBLY - STAINLESS STEEL
	7003-905-020	SENSOR OP APRON ASSEMBLY - GRAY
	7003-905-004	SENSOR OP APRON ASSEMBLY - STAINLESS STEEL
29	7003-093-001	FLOW RESTRICTOR - LOW-FLOW BUBBLER ONLY
30	7003-095-001	VALVE ASSEMBLY
31	7003-099-000	PUSH BUTTON
32	7003-830-000	UNIVERSAL MAINTENANCE TOOL
33	0124-031-000	#8 x 3/8" LNG SLOTTED HEX WASHER HD SCREW
34	7001-200-001	SOLENOID/VALVE MOUNTING ASSEMBLY
35	7003-029-199	SENSOR BRACKET, SENSOR OP
36	2563-385-002	NANO SENSOR ASSEMBLY
37	7001-203-199	SENSOR SPACER WITH BUSHING
38	0308-009-000	#8-32 NYLON INSERT LOCKNUT
39	0331-023-000	#8 S/S FLAT WASHER
40	0711-407-199	POWER SUPPLY, 240VDC
41	7003-028-199	TRANSFORMER BRACKET
42	7000-059-199	1-1/4" - 18 NORMALLY OPEN VALVE CAP
43	7003-023-199	CARTRIDGE MTG BRACKET, SENSOR OP
44	7000-050-001	VALVE CARTRIDGE ASSEMBLY
45	1895-715-000	1/4" PLUG
46	1895-710-000	1/4" O.D. PUSH-IN TEE
47	0711-451-001	3 STATION 9VAC WIRING HARNESS

Repairs must be made with Murdock Manufacturing parts only. Please order through your local representative or distributor.