



Haws[®]

OWNER'S MANUAL

1455 Kleppe Lane ♦ Sparks, NV 89431-6467 ♦ (888) 909-4297

♦ website: www.BritaHydrationStation.com

No. 2076718 (1)

**Model 2000
Brita[®] Hydration Station[™]**

LIMITED WARRANTY

HAWS[®] warrants that all of its products are guaranteed against defective material or poor workmanship for a period of **three years from date of shipment**. HAWS liability under this warranty shall be discharged by furnishing without charge F.O.B. HAWS Factory any goods, or part thereof, which shall appear to the Company upon inspection to be of defective material or not of first class workmanship, provided that claim is made in writing to company within a reasonable period after receipt of the product. Where claims for defects are made, the defective part or parts shall be delivered to the Company, prepaid, for inspection. HAWS will not be liable for the cost of repairs, alterations or replacements, or for any expense connected therewith made by the owner or his agents, except upon written authority from HAWS, Sparks, Nevada. HAWS will not be liable for any damages caused by defective materials or poor workmanship, except for replacements, as provided above. Buyer agrees that Haws has made no other warranties either expressed or implied in addition to those above stated, except that of title with respect to any of the products or equipment sold hereunder and that HAWS shall not be liable for general, special, or consequential damages claimed to arise under the contract of sale. The Brita[®] Hydration Station[™] manufactured by HAWS is warranted to function if installation and maintenance instructions provided are adhered to. The units also must be used for the purpose for which they were intended.

NO OTHER WARRANTIES EXPRESSED OR IMPLIED ARE AUTHORIZED, PROVIDED OR GIVEN BY HAWS.

SHOULD YOU EXPERIENCE DIFFICULTY WITH THE USE OF THIS MODEL, OR REQUIRE REPLACEMENT PARTS, PLEASE CALL:

**TECHNICAL SUPPORT:
1-800-766-5612**

HOURS OF OPERATION: MON-THURS 6:00a.m. - 4:00p.m. PT, FRI 6:00a.m. -2:00p.m. PT

QUICK START REFERENCE (SEE INSTALLATION INSTRUCTIONS FOR FURTHER DETAILS)

RATED SERVICE FLOW: 0.5 GPM (2725L/day) **OPERATING PRESSURE:** 30-90 PSI
OPERATING TEMPERATURE: 35-100 °F (1.7-37.8 °C) **FILTER CAPACITY:** 2400 gallons (9085L)
REPLACEMENT FILTER CARTRIDGE: Brita[®] Filter Model 6424

WATER SUPPLY REQUIREMENTS: 30-90 PSI (2-6 ATM) supply; cold water only.

Do not use with water that is microbiologically unsafe or of unknown quality without adequate disinfection before or after the system. Systems certified for cyst reduction may be used on disinfected waters that may contain filterable cysts.

WASTE REQUIREMENTS: An acceptable trap must be used after the waste bend.

NOTE: When installing this unit, all pertinent local, state, or federal codes should be adhered to.

© 2010 Haws[®] Corporation – All Rights Reserved

HAWS[®] and other trademarks used in these materials are the exclusive property of Haws Corporation.

The BRITA trademark and logo are registered trademarks of Brita, LP and used under license by Haws Corporation. All rights reserved.

BRITA Trademark Usage Guidelines

The Brita trademark and Brita logo (collectively, the “Brita Marks”) are among the most critical elements of Brita, LP’s identity and convey many aspects of our business. The Brita Marks are widely recognized, positive industry symbols and can be a very effective way to highlight your commitment to the environment and providing high quality drinking water to your patrons.

The following guidelines apply to customers of the Brita® Hydration Station™ water dispensing units and Brita® filters.

Your purchase of this Brita® product authorizes your company to use and/or display the Brita Marks as long as:

- You continue to use Brita® filters in the Brita® Hydration Station™ water dispensing unit and replace the Brita® filters as instructed
- You maintain your Brita® product at an appropriate level to provide high quality drinking water to your patrons
- You do not disparage Brita, LP or Brita® products
- You do not imply a relationship or association with Brita, LP that does not exist
- You adhere to these Trademark Usage Guidelines

Improper use of the Brita Marks may be considered a violation of these Trademark Usage Guidelines, and Brita, LP reserves all rights to enforce proper use of its trademarks, including but not limited to having you remove or cover up the Brita Mark on the product.

In the event you have questions about the proper use of the Brita Marks, the Brita® filters or the Brita® Hydration Station™ water dispensing unit, please call 888-909-4297 to be connected to a representative of Haws Corporation. The Brita Marks are registered trademarks of Brita, LP and are used under license by Haws Corporation.

Haws Corporation
1455 Kleppe Lane • Sparks, NV 89431
1-888-909-4297
www.Britahydrationstation.com

Trademark Use Guidelines (TUG)

- **Before first use**, the installer will need to remove the bright orange TUG label over filter head (see right), thereby accepting the guidelines.
 - The TUG label reads as follows: ***Removal of this label signifies you or an appropriate owner’s agent will comply with all BRITA® Trademark Usage Guidelines as well as maintain the unit to the standards as first installed. Detailed information noting requirements can be found within the unit as well as in the Owner’s Manual on Page 2.***
- The complete Trademark Usage Guidelines are located in 2 places for reference by owner/maintenance personnel.
 - Within the Brita® Hydration Station™ unit.
 - Above

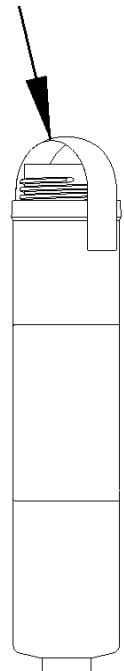

Maintenance Label

- When installation of the Brita® Hydration Station™ is complete, **obtain a phone number for the sales representative that sold you the unit.** Write this number into the maintenance label located in the lower right-hand corner of the front of the unit (see below) and use for maintenance and troubleshooting questions.
- If any issues or questions arise that cannot be addressed by this Owner's Manual, refer to this label, which also contains the Haws® (888) 909-4297 customer service phone number and a serial number for tracking.

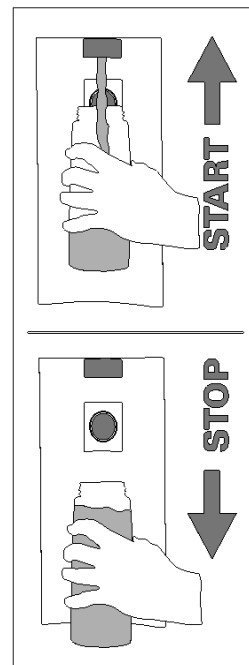
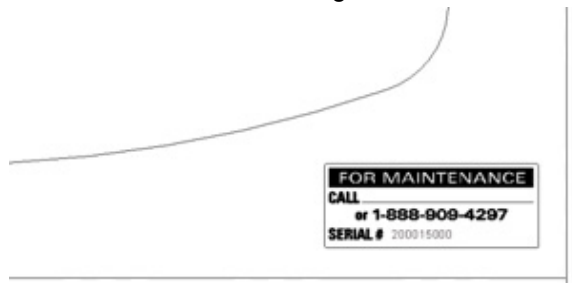

General Operation

- Approach the Brita® Hydration Station™ with a bottle (or other multi-use water container). Note the start/stop activation label (seen to right) at the center of the unit – in & up to activate; down & out to deactivate.
- Place the bottle in the opening and move upward to the sensor (see below).
- When the sensor detects the bottle, a blue light will activate to help position the bottle under the nozzle. After a slight delay, water will dispense.
- When the bottle is filled, lower it from the sensor to stop the water flow.
 - There is a 30 second shut-off feature to prevent needless dispensing.

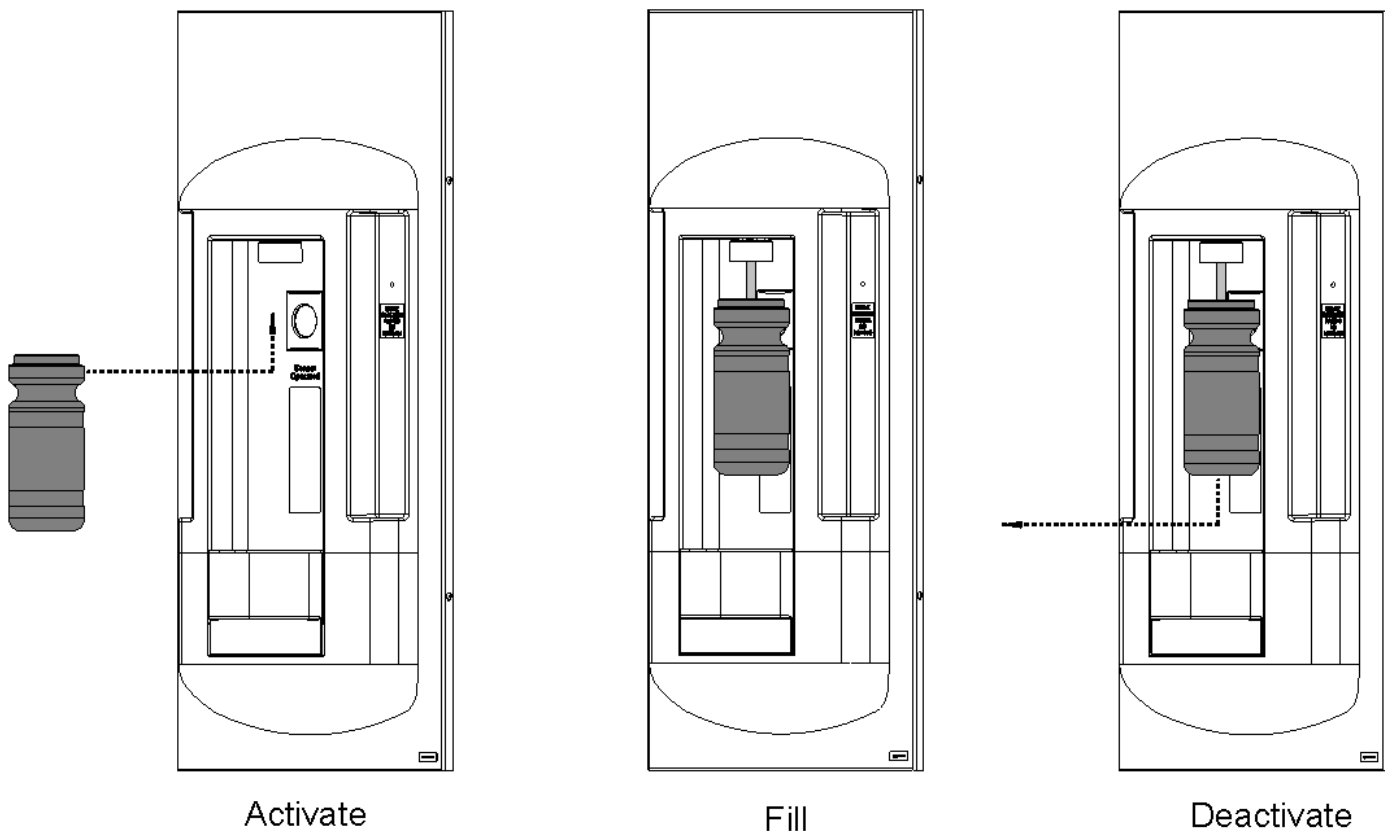

General Operation (continued)

- During activation, the LED light to the far right of the sensor (see right) will flash **green** several times, indicating that the filter is working properly. This same LED will change to a **blinking yellow** when filter life reaches 10% remaining (filter change recommended), and then to a **blinking red** when the filter has reached end of life (filter change necessary).

A solid red light indicates that the two AA batteries in the filter monitor must be replaced.

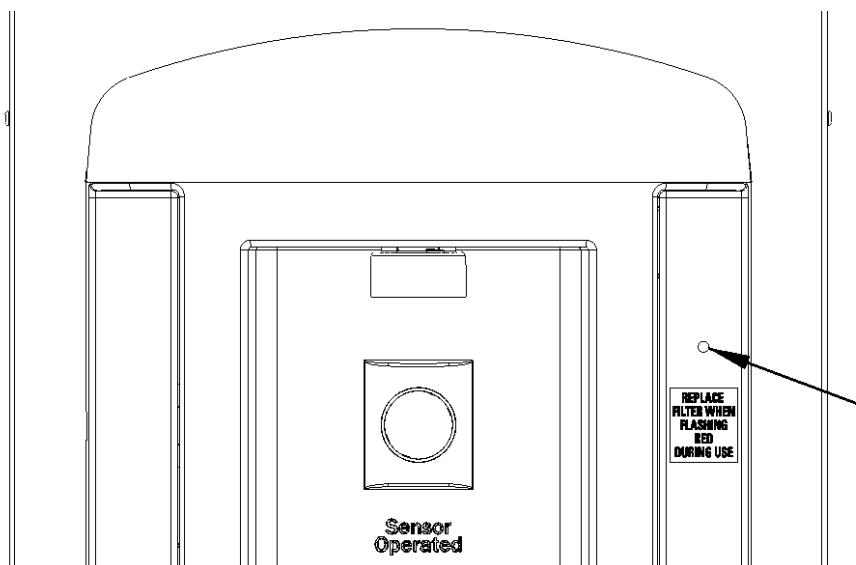

Auto Purge & Periods of Inactivity

- The Brita® Hydration Station™ is designed to purge itself after every 24 hours of non-use. This effectively removes the standing water from the system and introduces new water in an effort to prevent the growth of bacteria.
- If there is a period of several days during which the Brita® Hydration Station™ is either drained or disconnected from its water supply, the filter cartridge should be removed and discarded (see below) since the unit will not be able to self-purge. Install a fresh cartridge when the system comes back on line.

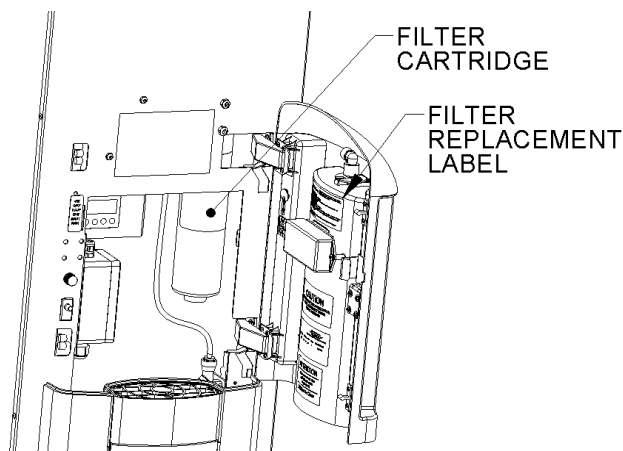

Water Quality

- The Brita® Hydration Station™ is not intended to purify water. Do not use this system with water that is microbiologically unsafe or of unknown quality without adequate disinfection before or after the system. Individuals requiring water of special microbiological purity should follow the advice of their doctor or local health officials regarding the use and consumption of their tap water.

Maintenance

WARNING:

1. Make certain power is disconnected before servicing to reduce the risk of electrical shock.
2. Do not touch any circuit board for any reason.

CAUTION: Do not use an abrasive cloth, brush, polishing compound, or abrasive cleaner to clean any part of the unit.

Filter Replacement & Filter Monitor Reset

- For filter replacements, please contact Haws customer service at 1-888-909-4297, or visit www.BritaHydrationStation.com. It is recommended that at least one filter replacement is on hand for immediate replacement purposes.
- Maintenance personnel can determine filter life as outlined on page 4. The filter should be changed when the filter LED blinks yellow or red, or sooner if the water flow begins to decrease.
- **To open the unit**, slide the supplied hex key (or a long, small slotted screwdriver) into the notch in the left-hand side of the hinged upper panel and press the key firmly in that same direction. This will disengage the internal spring latch. Simultaneously pull open the hinged panel. Take care not to damage the stainless steel panel or the spring latch in this process.
 - NOTE: Opening the hinged panel cuts the power to the sensor and the solenoid valve, preventing accidental activation.

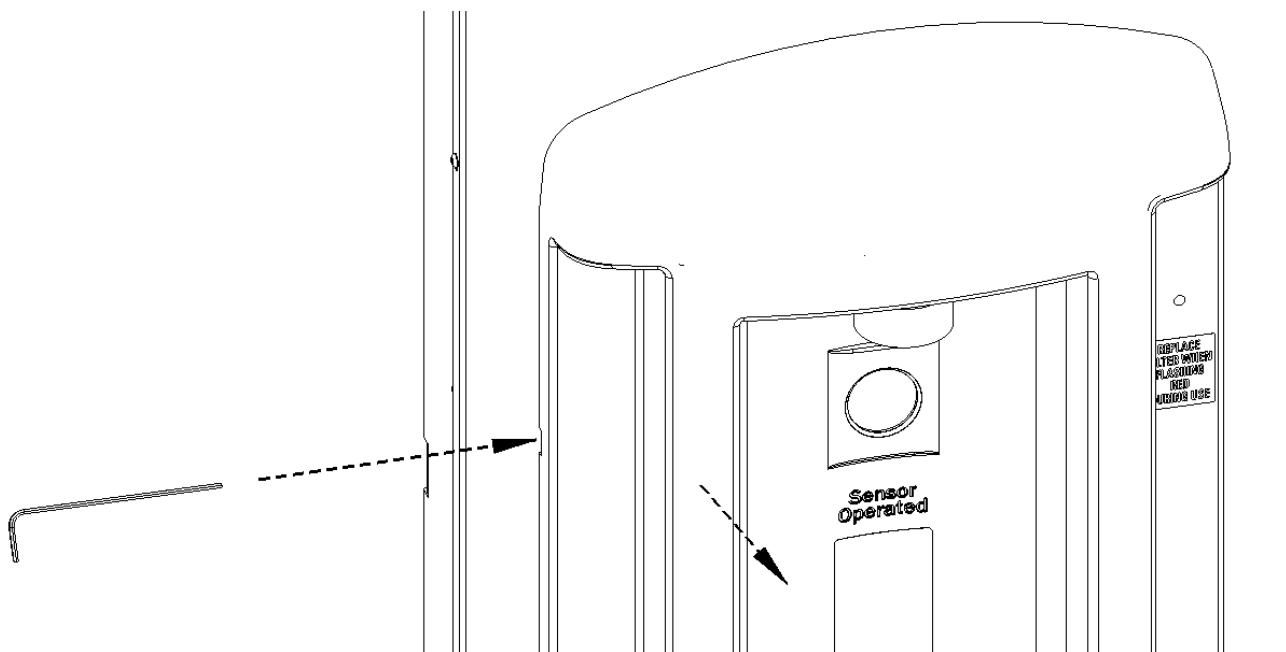

Maintenance (continued)

- An instructional label is visible when the hinged panel is opened, noting how to replace the filter (see below).
 - NOTE: Water does not need to be shut off to replace the filter cartridge; however, it should be shut off if the filter head is going to be left without a cartridge installed for a long period of time.

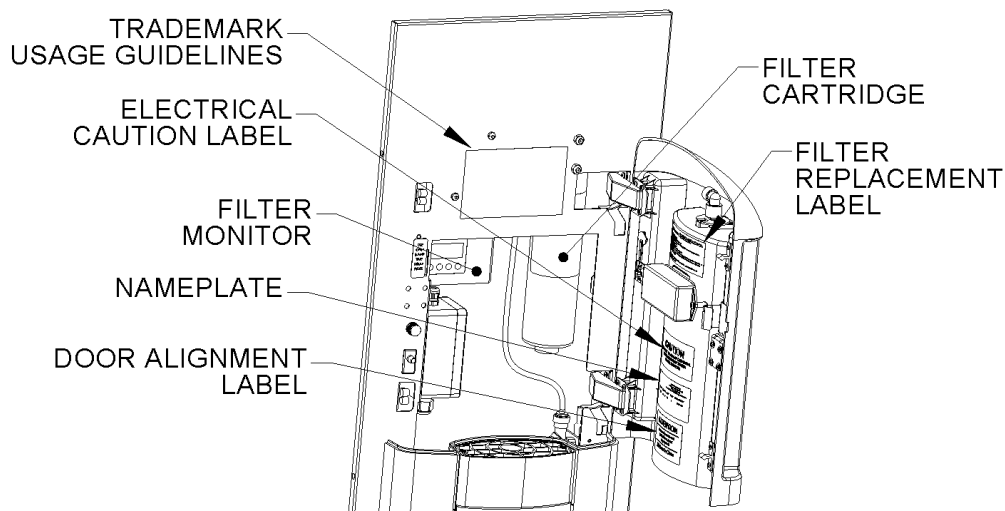

1. Unscrew old filter cartridge.
2. Screw new cartridge firmly into filter head.
3. Reset the filter monitor by pressing the “Pwr/Stg” button on the filter monitor base unit (unless display is already on).
4. Press the “Set” button once, then press & hold the “Set” button for 2 seconds.
5. Run water briefly through unit to assure that the filter LED flashes green upon activation. If it does not, consult the Troubleshooting Guide.
6. Open unit and examine to assure that there are no leaks.
7. Water should be run through the system for **approximately five minutes** after the cartridge is installed in order to remove the loose carbon particles from the filter cartridge and any air bubbles from the system.

Battery Replacement

- If the filter LEDs shows a solid red light, replace the two AA batteries in the filter monitor by pulling the monitor off of its Velcro mount and opening the battery compartment in the back.

Purge Cycle & Cleanliness

- For hygienic purposes, the unit purges itself briefly if it has not been used in 24 hours. However, it is recommended that the drain basin be regularly cleaned and disinfected with Clorox® Regular Bleach – use ¼ cup Clorox® bleach and mix in 1 gallon of water. Pour slowly throughout the drain basin and let stand for 5 minutes. Flush with water and let air dry.
 - To access the drain basin for cleaning, open the hinged upper panel and remove the two screws holding the drain grate in place with a T-20 Torx tool (see right).
- The sensor lens should be wiped clean with a soft cloth if it has become dirty; this will help to ensure superior sensor performance. Never spray cleaners directly at the sensor. The rest of the unit may be cleaned with a mild sanitizing cleaner, such as Clorox® Anywhere® Hard Surface™ Daily Sanitizing Spray.

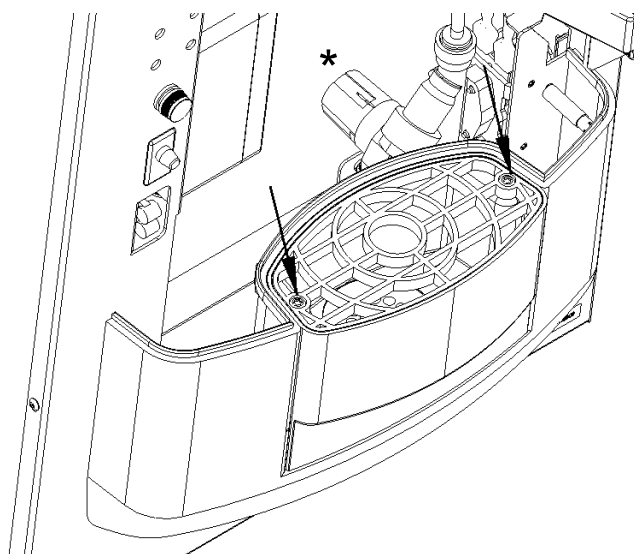

The Clorox® trademark and logo are registered trademarks of the Clorox Company. All rights reserved.

BRITA® HYDRATIONSTATION™ TROUBLESHOOTING

PROBLEM	REPAIR CHECKLIST
1. Low water flow.	<ul style="list-style-type: none"> a. Change filter cartridge. b. Verify minimum 30 psi supply pressure. c. Check that the inlet screwdriver stop valve (not supplied) is in the wide-open position. d. Check that pressure regulator is open (in picture at bottom of page 6; marked with asterisk – pull knob out and rotate counterclockwise from front of unit). e. Clean solenoid valve inline strainer (above the regulator). f. Contact Haws Technical Support @ 1-800-766-5612.
2. Filter monitor LED does not indicate flow (i.e. LED is not flashing) when water is dispensing.	<ul style="list-style-type: none"> a. Check that both the LEDs and the flow sensor are correctly plugged into the filter monitor base unit (i.e. sensor should be plugged into “Sensor” port). If they are not, remove a battery (rear of filter monitor), plug in the devices correctly, and replace the battery. b. Replace batteries. c. Contact Haws Technical Support @ 1-800-766-5612.
3. Unit activates by itself.	<ul style="list-style-type: none"> a. Check sensor window for any obstructions. Remove obstructions; clean sensor area. b. Contact Haws Technical Support @ 1-800-766-5612.
4. Water will not flow.	<ul style="list-style-type: none"> a. Check sensor window for obstructions; if it is obstructed, it may have automatically timed out after 30 seconds and will not reactivate until the obstruction has been cleared. b. Make sure the unit is receiving power (look at nozzle from underneath – if the unit has power, the LEDs will be flashing). c. Check to see if fuse has blown (fuse holder is located behind hinged upper panel, below the fuse information label) and replace if necessary. Use only Bussmann MDL-1/4” 0.25A time-delay fuses. d. Check that any inlet screwdriver stop valve is in the wide-open position. e. Replace filter. f. If nozzle LEDs activate when an object trips the sensor, but no water dispenses, listen for a click or a hum to indicate that the solenoid is functioning. If nothing is heard, proceed to Step g. g. Contact Haws Technical Support @ 1-800-766-5612.
5. Water is observed anywhere other than the outlet nozzle.	<ul style="list-style-type: none"> a. Shut off water supply and contact Haws Technical Support @ 1-800-766-5612.

BRITA® HYDRATIONSTATION™ TROUBLESHOOTING (CONTINUED)	
PROBLEM	REPAIR CHECKLIST
6. Water excessively splatters in drain.	<ul style="list-style-type: none"> a. Turn down pressure regulator (in picture at bottom of page 6; marked with asterisk – pull knob out and rotate clockwise from front of unit). b. Check to assure that mesh screens are still visible in end of nozzle c. Examine nozzle for debris and clean if necessary (nozzle may be unbolted from inside with a T-15 Torx tool).
7. Sensor trips randomly/sporadically.	<ul style="list-style-type: none"> a. Unit is designed to self-purge every 24 hours that it is not used. b. Contact Haws Technical Support @ 1-800-766-5612.
8. Filter monitor LED is blinking yellow or red when unit is used.	<ul style="list-style-type: none"> a. Replace filter cartridge and reset filter monitor.
9. Filter monitor LED is solid red when unit is used.	<ul style="list-style-type: none"> a. Replace the 2 AA filter monitor batteries (remove monitor from its Velcro mount; access batteries through the cover in the rear of the monitor).
10. Filter monitor will not reset.	<ul style="list-style-type: none"> a. Turn on the filter monitor display and press “Pwr/Stg” button until the stage 1 is selected. Press the “Set” button. The word “Set” should appear at the top of the display. Press the “Pwr/Stg” button until the right-hand column (“2400 G”) is selected Press and hold the “Set” button until it beeps.

PERFORMANCE DATA SHEET

IMPORTANT NOTICE: Read this Performance Data Sheet and compare the capabilities of this unit with your actual water treatment needs. It is recommended that, before purchasing a water treatment unit, you have your water supply tested to determine your actual water treatment needs.

Substance	Influent Challenge Concentration	Reduction Requirement	Maximum Permissible Product Water Concentration	Average Percent Reduction
Chlorine, Taste and Odor	2.0 mg/L \pm 10%	\geq 50%	N/A	96.6%
Lead	0.15 mg/L \pm 10%	N/A	0.010 mg/L	99%
Cyst	Minimum 50,000/L	99.95%	N/A	99.99%

This system has been tested according to NSF/ANSI 42/53 for the reduction of the substances listed. The concentration of the indicated substances in water entering the system was reduced to a concentration less than or equal to the permissible limit for water leaving the system, as specified in NSF/ANSI 42/53.

Testing was performed under standard laboratory conditions. The contaminants or other substances removed or reduced by this water treatment device are not necessarily in all users' water. Filter performance may vary based on local water conditions.

© 2010 Haws® Corporation – All Rights Reserved
HAWS® and other trademarks used in these materials are the exclusive property of Haws Corporation.

The BRITA trademark and logo are registered trademarks of Brita, LP and used under license by Haws Corporation. All rights reserved.