



**Pedestal Fountain**

**MODEL 4591**



This fountain is certified to NSF/ANSI 61.

**GENERAL**

Pedestal, weather-resistant exposed Sierra™ stone aggregate fountain for year-round beauty with minimum maintenance. Contour-formed stainless steel basin with rounded corners and edges reduces splatter, insures proper drainage and prevents standing waste water.

**BUBBLER**

Single-stream, self-closing, pushbutton operated with integral volume control for maintaining proper stream height. Also includes hood guard and anti-squirt feature.

**ACCESS PANEL**

Manufactured of heavy-gauge steel with vandal-resistant self-locking screws. Baked on enamel protective coating is resistant to wear, moisture, and sunlight. Provides access for easy hookup of all plumbing connections.

**AUTOMATIC STREAM HEIGHT REGULATOR**

Self-closing assembly is located inside unit to prevent tampering. Unit resists corrosion and liming. A constant stream height is automatically maintained under line pressures that vary from 20 to 105 psi.

**INLET STRAINER**

Easily cleaned in-line strainer screen traps particles of 140 microns or larger before they enter the waterway.

**WATER INLET**

3/8" O.D. Tubing

**DRAIN OUTLET**

1-1/4" tube outlet for 1-1/4" slip joint connection.

**SUGGESTED SPECIFICATIONS**

Fountain shall be upright pedestal with exposed Sierra™ stone aggregate. Shall include contour-formed stainless steel basin to eliminate splashing and standing water, and shall have rounded corners and edges. Projector shall be single-stream with integral hood guard and anti-squirt feature. The manufacturer shall certify the unit to meet the requirements of NSF/ANSI 61, and the Safe Drinking Water Act.

Note: Continued product improvement makes specifications subject to change without notice. See Halsey Taylor website for most current spec sheet.



Standard finish is Stone aggregate

Trap and service stop not included.

Shipping weight: 155 lbs.

JOB NAME: \_\_\_\_\_  
 \_\_\_\_\_  
 \_\_\_\_\_  
 ENGINEER/CONTRACTOR NAME: \_\_\_\_\_  
 \_\_\_\_\_  
 APPROVAL: \_\_\_\_\_  
 DATE: \_\_\_\_\_



4591

## Upright Stone Pedestal Fountain

(CONTINUED)

### MOUNTING INSTRUCTIONS and PLUMBING CONNECTIONS

Provide solid, well-drained surface to mount pedestal fountain (concrete pad recommended). (4) 1/2" anchor bolts (not included) should be attached securely to mounting surface in order to secure fountain. (Refer to rough-in diagram.)

Locate and install plumbing through ground as required.

NOTE: Fountain is not furnished with service valve.

Position pedestal over plumbing and secure base to anchor bolts. Remove access panel and connect supply and water lines. Remember to check your local plumbing and other applicable codes before installation.

Turn on water supply, check for leaks.

Reassemble access panels to pedestal.

**Trap and service stop not included.**

### OPERATING PRESSURES

Supply water-105 psi maximum

TOP VIEW

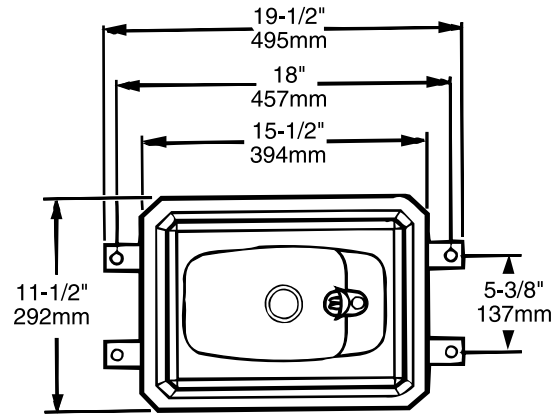

FRONT VIEW

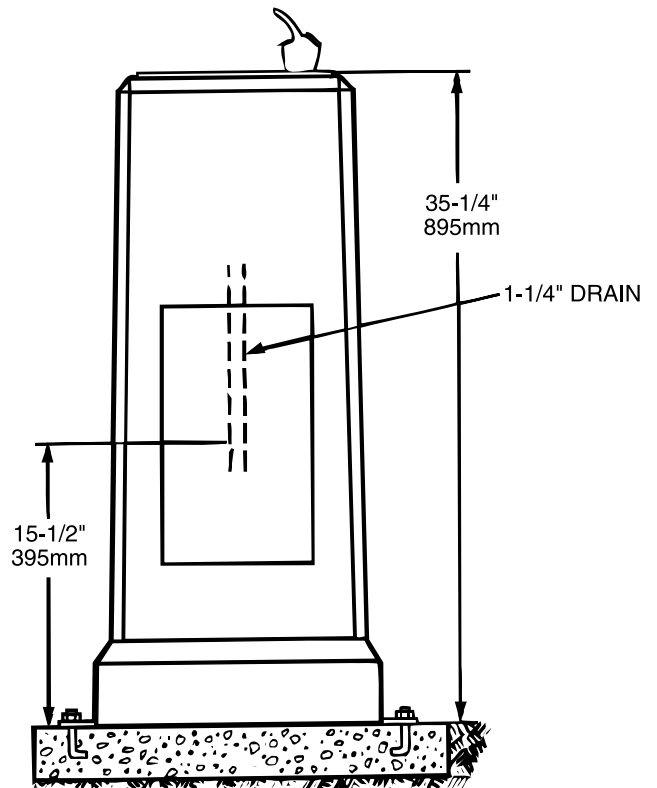

*Halsey Taylor*®