

**No Lead SwirlFlo® Drinking Fountain
Wall Mount-Fully Exposed with Wall Plate
Barrier-Free Access
Model EDFPBWM114C**



SPECIFICATIONS

GENERAL

Wall mounted drinking fountain basin constructed of #18 gauge, type 304 stainless steel polished to a lustrous satin finish with high shined outer edge. #16 gauge, type 304 tubular stainless steel support arm incorporates a recess to be integrated with basin.

Contoured basin minimizes splashing and has exclusive Flexi-Guard® safety bubbler to prevent accidental mouth injuries. Keyed in location to prevent rotation. Fully functional, vandal-resistant front push button is easy to operate. Patented* valve and in-line flow regulator provides constant stream from 20 to 105 psi. Vandal-resistant bottom cover plate.

THIS WATER COOLER COMPLIES WITH THE REQUIREMENTS OF A.D.A. (AMERICANS WITH DISABILITIES ACT).

NO LEAD DESIGN

THIS DRINKING FOUNTAIN COMPLIES WITH THE LEAD-FREE DEFINITION IN THE SAFE DRINKING WATER ACT OF 1986 AND LEAD CONTAMINATION CONTROL ACT OF 1988.

Elkay Drinking Fountains are manufactured with a waterway system utilizing copper components and completely lead-free material. These waterways have no lead because all leaded materials, such as leaded brass, have been removed.

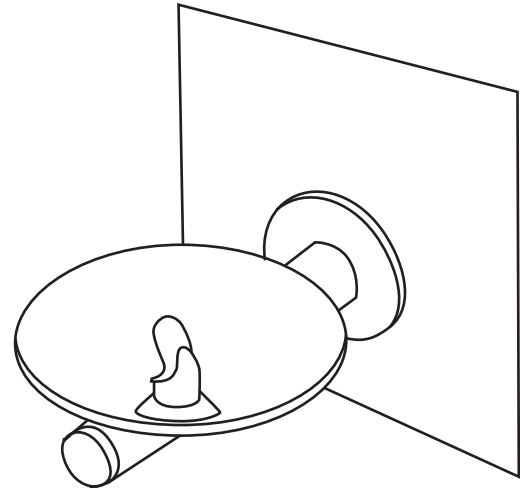

Model EDFPBWM114C



This drinking fountain is classified by Underwriters Laboratories Inc. in accordance with **ANSI/NSF61, Section 9-1997b.**

CONSTRUCTION

EDFPBWM114C furnished complete with Flexi-Guard® fully assembled front push button, patented* valve and in-line flow regulator (20 to 105 psi) with surface mounting plate and stainless steel wall plate. No trap furnished.

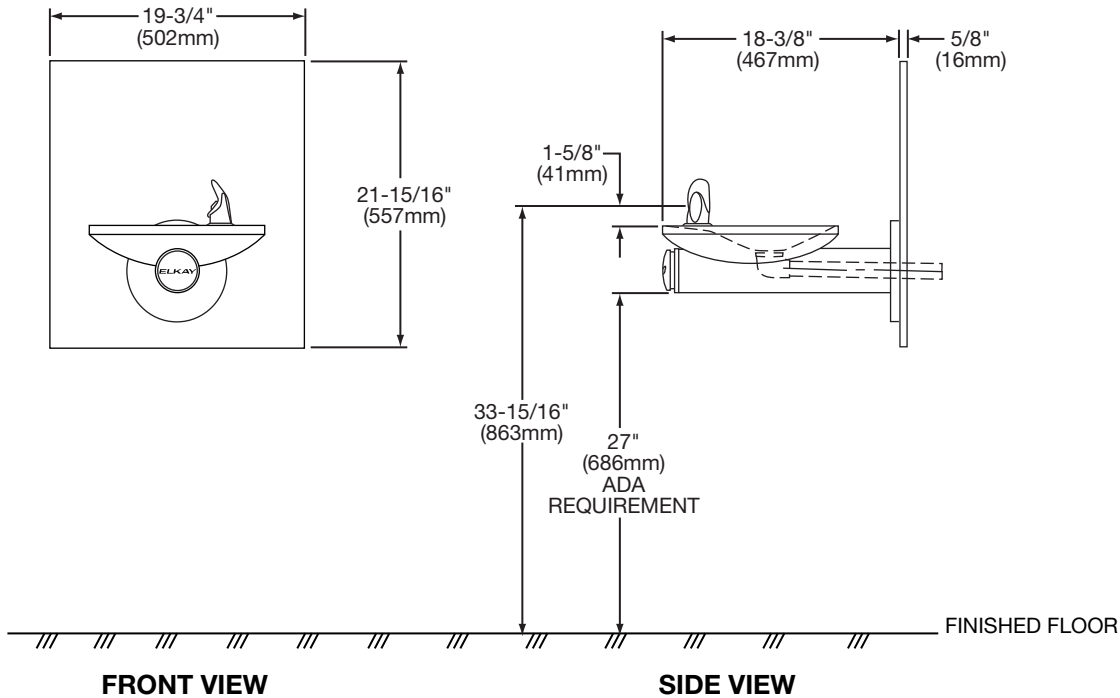

* Patent #4,481,971

In keeping with our policy of continuing product improvement, Elkay reserves the right to change product specifications without notice.

This specification describes an Elkay product with design, quality and functional benefits to the user. When making a comparison of other producers' offerings, be certain these features are not overlooked.

**No Lead SwirlFlo® Drinking Fountain
Wall Mount-Fully Exposed with Wall Plate
Barrier-Free Access
Model EDFPBWM114C**



ROUGH-IN DIMENSIONS

INSTALLER NOTE

THIS DRINKING FOUNTAIN IS FURNISHED WITH A BUBBLER AND VALVE INCLUDING ALL CONNECTING FITTINGS WHICH ARE MANUFACTURED OF COMPLETELY LEAD-FREE MATERIAL. IT IS RECOMMENDED THAT SHUT OFF VALVE AND SUPPLY TUBING SUPPLIED BY OTHERS BE NON-METALLIC.

OPERATION OF QUICK CONNECT FITTINGS

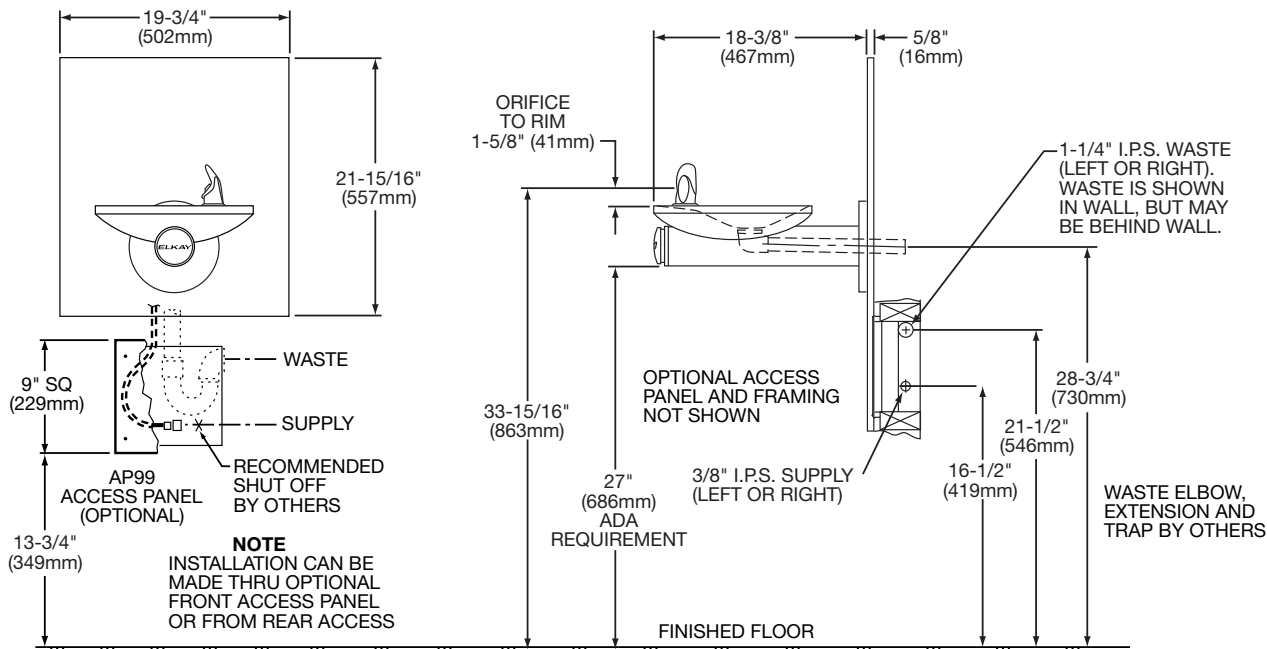
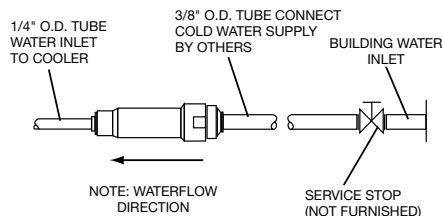
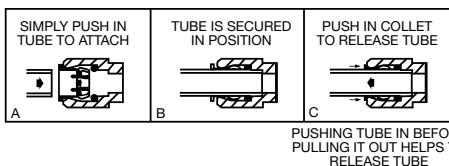

SUPPORT PREPARATION

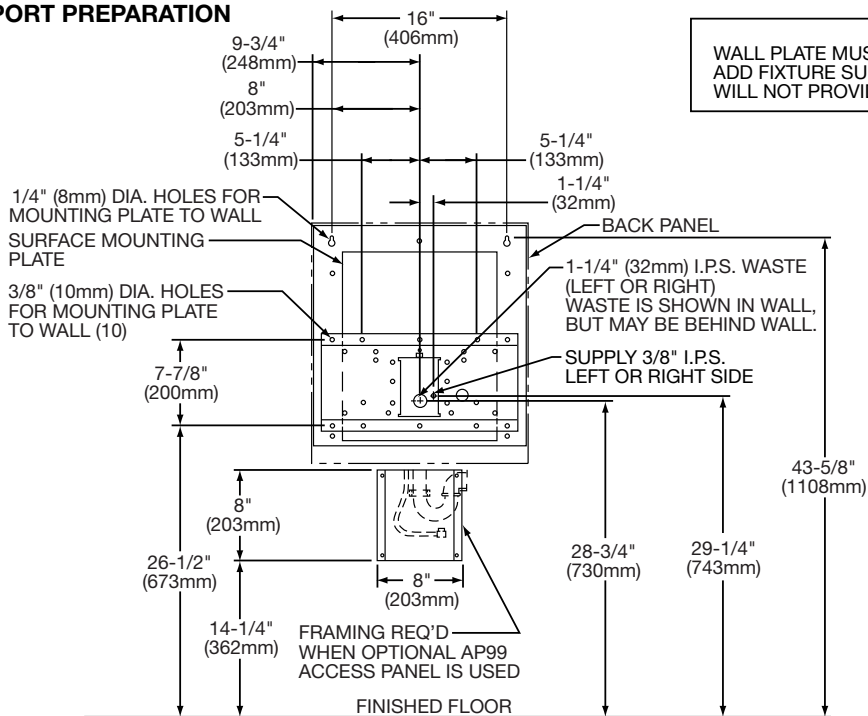

NOTE
WALL PLATE MUST BE SUPPORTED SECURELY. ADD FIXTURE SUPPORT CARRIER IF WALL WILL NOT PROVIDE ADEQUATE SUPPORT.