

1001HPSMS

Wall Mounted Drinking Fountain



FEATURES & BENEFITS

Quality Control

Fountain is pre-built and fully water and pressure tested to ensure no leaks and proper function for reduced installation time and added peace of mind.

Construction

18 gauge Type 304 Stainless Steel fountain with attractive and functional swirl bowl design, along with a vandal-resistant bottom plate provides a long lasting unit with added peace of mind.

Bubbler Head

Polished chrome-plated brass bubbler head with integral laminar flow prevents splashing and provides a superior flow pattern. The integral basin shank and inserted roll pin adds vandal resistance strength to the design, and the shielded angled stream orifice produces a steady sanitary source of water.

Mounting

3/16" steel mounting plate with supplied mounting hardware provides a solid unit base and allows for easy installation to a framed wall.

Push Button

With its patented (Pat.# 6,981,692) push-button valve assembly which allows for front access stream adjustment as well as cartridge and strainer access, this fountain offers the ultimate in ease of maintenance.



SPECIFICATIONS

Model 1001HPSMS wall mounted barrier-free drinking fountain shall include an 18 gauge Type 304 high-polished stainless steel finish basin with integral swirl design with matching back and access panel allowing for front access of P-trap and stop, in-wall mounting frame, push-button operated valve with front-accessible cartridge and flow adjustment, polished chrome-plated brass vandal-resistant bubbler head with integral laminar anti-squirt flow, chrome-plated brass vandal-resistant waste strainer, vandal-resistant bottom plate, and 1-1/4" O.D. waste pipe.

OPTIONS

- Bubbler Head: Model 5725 EnviroGard™ bubbler is a polished chrome-plated solid brass bubbler head with stainless steel water activated pop up canopy. (Pat.# 7,025,282)
- Filter: Model 6426, 12" x 2", in-line lead removal element that reduces lead from incoming water supply.
- Chiller: Model HCR8, chiller provides for instantaneous cooling to meet a continuous demand for chilled water.
- Premier Finishes: Haws standard satin or high polished finishes in stainless steel can be modified to have rose or gold Physical Vapor Deposition (PVD) finish. Specify model with finish by name.

APPLICATIONS

Perfect for either public or private indoor/outdoor settings, Model 1001HPSMS is a great fit in areas where aesthetics are important to the overall appeal of the architecture. This series is precisely mounted, making it a nice addition to any surrounding. Beautiful high-polished finish helps to maintain the fountains overall appeal so it always remains looking as new as it did when it was installed. Specifically, this type of wall mounted drinking fountain may be placed in settings such as: schools and other locations in and around office buildings where the temperature remains above freezing.

Model meets all current Federal Regulations for the disabled including those in the Americans with Disabilities Act. Haws manufactures drinking fountains, electric water coolers and electric drinking fountains to be lead-free by all known definitions including ANSI/NSF Standard 61, Section 9, California Proposition 65, and the Federal Safe Drinking Water Act.



NOTES:

1. HOLD ROUGH-IN DIMENSIONS ± 1/8" (3.2mm).
2. WHEN INSTALLING THIS UNIT, LOCAL, STATE, OR FEDERAL CODES SHOULD BE ADHERED TO FOR INSTALLATION DIMENSIONS (LOCATIONS), WASTE AND SUPPLY REQUIREMENTS OTHER THAN SHOWN.
3. ** INSTALLER MUST PROVIDE TRAP FOR PROPER INSTALLATION.

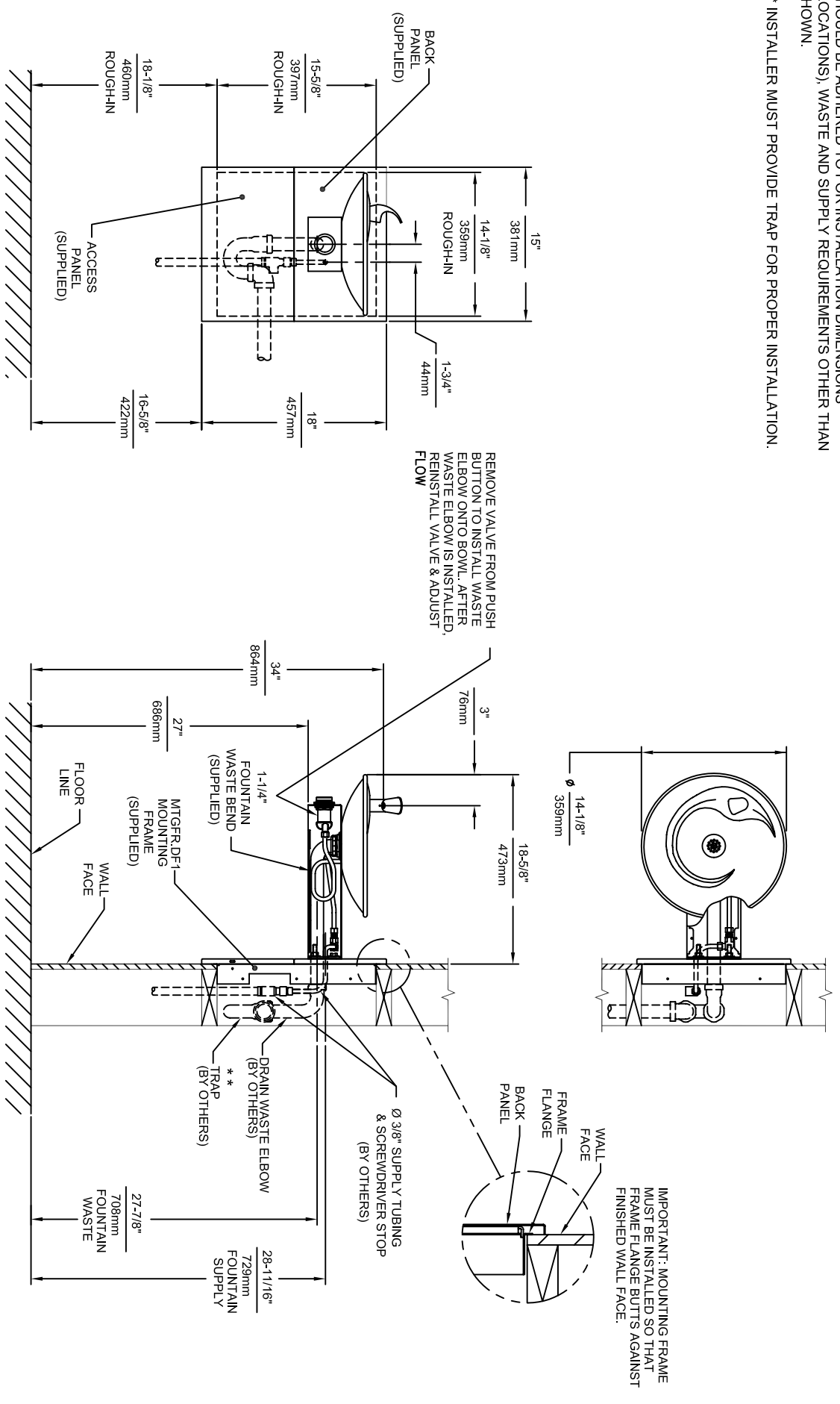

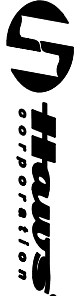
		INFO FAX : 1-888-FAX-HAWS (1-888-329-4297) 1455 Kiappa Ln, Sparks NV, 89431 Phone: 775-359-4712 Fax: 775-359-7424 Haws AG Buchweg 3 CH-3401 Burgdorf Switzerland Haws King Pte Ltd 74 Sungai Kodut Loop Singapore 729531 e-mail: Haws@hawsco.com website: www.hawsco.com	
ORDER NO. 1001MS/1001HPSMS DATE: 8/02/99 APPROVED:	REVISIONS: NONE CHECKED:	MODEL(S): 1001MS/1001HPSMS INFO FAX DOC #: 2100167/2100147767 SCALE: 1:1X DRAWING TYPE: INSTALLATION/FABR/CAD	ORDER NO. 14221A00 QTY 1 SIZE A SHEET 1 OF 1



INSTALLATION, OPERATION & MAINTENANCE INSTRUCTIONS

1455 Kleppe Lane ♦ Sparks, NV 89431-6467 ♦ (775) 359-4712 ♦ Fax (775) 359-7424
HAWS AG ♦ Bachweg 3 ♦ CH-3401 Burgdorf ♦ Switzerland
Haws Mfg. Pte Lt. ♦ 2A Sungei Kadet Drive ♦ Singapore 729554
Avlis-Avenida Senador, Testonio Vilela ♦ 505 Jardim Aeroporto ♦ Itu, S.P. 13304-550 ♦ Brasil
E-mail: haws@hawsco.com ♦ website: www.hawsco.com

No. 2076510 (5)

Model 1001MS/1001HPSMS Drinking Fountain

NOTE TO INSTALLER: Please leave this information with the Maintenance Department.

LIMITED WARRANTY

HAWS® warrants that all of its products are guaranteed against defective material or poor workmanship for a period of **one year from date of shipment**. HAWS liability under this warranty shall be discharged by furnishing without charge F.O.B. HAWS Factory any goods, or part thereof, which shall appear to the Company upon inspection to be of defective material or not of first class workmanship, provided that claim is made in writing to company within a reasonable period after receipt of the product. Where claims for defects are made, the defective part or parts shall be delivered to the Company, prepaid, for inspection. HAWS will not be liable for the cost of repairs, alterations or replacements, or for any expense connected therewith made by the owner or his agents, except upon written authority from HAWS, Sparks, Nevada. HAWS will not be liable for any damages caused by defective materials or poor workmanship, except for replacements, as provided above. Buyer agrees that Haws has made no other warranties either expressed or implied in addition to those above stated, except that of title with respect to any of the products or equipment sold hereunder and that HAWS shall not be liable for general, special, or consequential damages claimed to arise under the contract of sale. The drinking fountain manufactured by HAWS is warranted to function if installation and maintenance instructions provided are adhered to. The units also must be used for the purpose for which they were intended.

NO OTHER WARRANTIES EXPRESSED OR IMPLIED ARE AUTHORIZED, PROVIDED OR GIVEN BY HAWS.

SHOULD YOU EXPERIENCE DIFFICULTY WITH THE INSTALLATION OF THIS MODEL, PLEASE CALL:

1-800-766-5612

FOR PARTS CALL:

1-800-758-9378

**(U.S.A. AND CANADA ONLY) MONDAY-THURSDAY: 6:00 A.M. – 4:00 P.M. PST
FRIDAY: 6:00 A.M. – 1:00 P.M. PST**

RECOMMENDED TOOLS: Hack saw, pipe joint sealant, screwdriver, level, 12" adjustable wrench, 10" pipe wrench, 3/32" and 5/32" hex key wrench, 9/16", 1/2", 7/16" socket wrench or open end wrench.

LOCATION OF UNIT: The Model 1001MS/1001HPSMS Drinking Fountain is a wheelchair accessible drinking water facility. The height dimensions shown, meet current ADA requirements. When installing this unit, local, state or federal codes should be adhered to. If height other than shown is required, then dimensions must be adjusted accordingly.

SUPPLY LINE: The minimum recommended line size is 1/2"IPS with 30-90 psi (2-6 ATM) pressure. Where sediment or mineral content is a problem, an inlet filter is recommended.

PLUMBING CONNECTIONS: Inlet is 3/8" O.D. compression fitting. Waste elbow outlet is 1-1/4" O.D. Tube.

MAINTENANCE: Periodically clean the strainer. Refer to 5874 Valve Manual for more information.

TROUBLESHOOTING	
PROBLEM	REPAIR CHECKLIST
1. Insufficient bubbler flow.	<ul style="list-style-type: none">1a. Check that inlet screwdriver stop valve is wide open.b. Verify minimum 30 psi flowing supply pressure.c. Clean strainer. See 5874 Valve Manual.d. Adjust valve to increase flow. Use front adjust screw or see 5874 Valve Manual.

ITEM	DESCRIPTION	1001MS	1001HPSMS
1	STRAINER	6463	6463PCP
2	BACK PANEL	BP6	BP6HPS
3	BUBBLER HEAD & INSERT	5705	5705
4	PUSH BUTTON ASSY	PBA6	PBA6
5	VALVE	5874	5874
6	BOTTOM PLATE	PBM1000	PBM1000
7	ACCESS PANEL	6606	6606HPS
8	MOUNTING FRAME	MTGFR.DF1	MTGFR.DF1
9	SPANNER WRENCH	0006983506	0006983506

PARTS BREAKDOWN

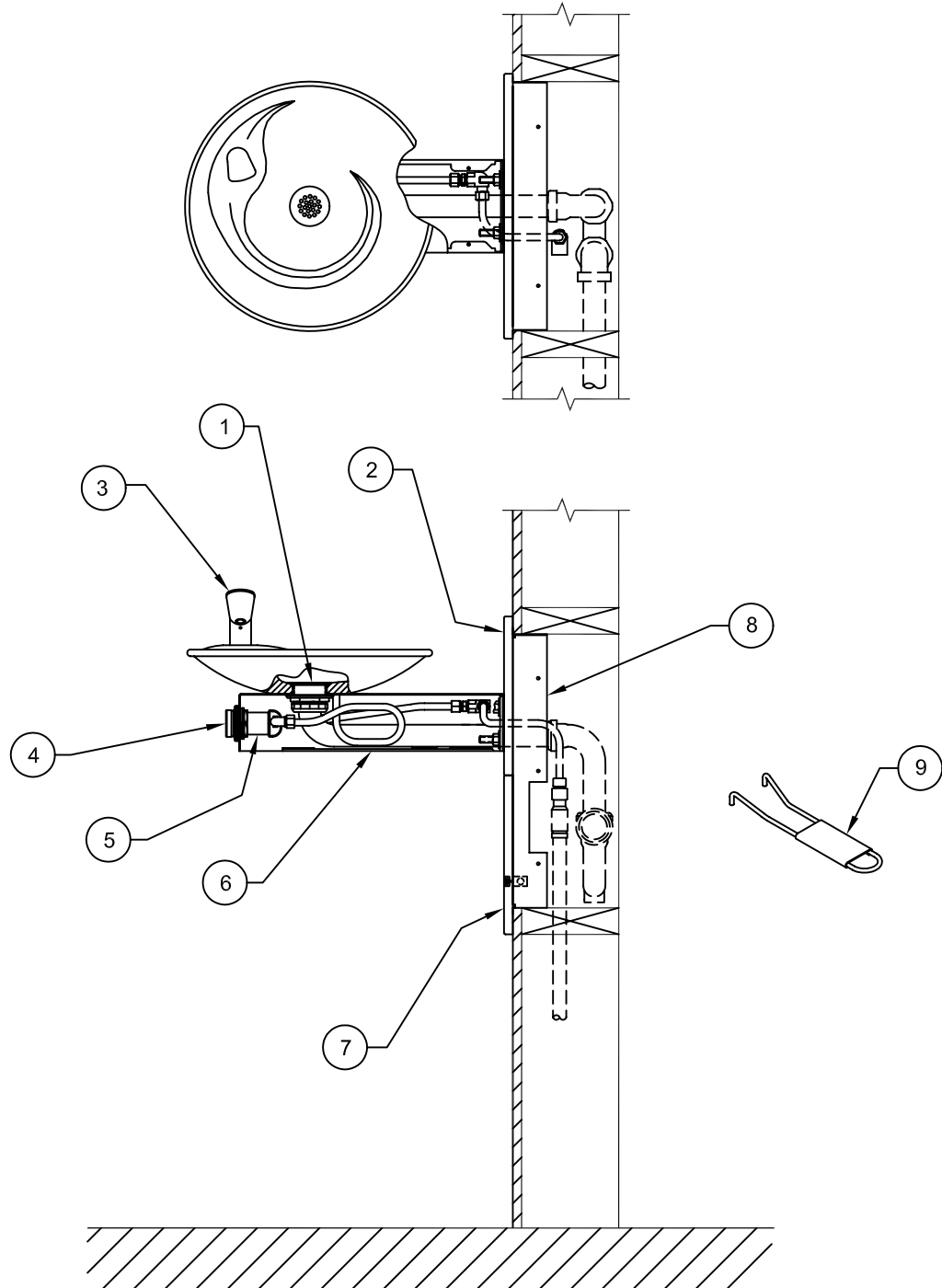

**WHEN ORDERING
PARTS PLEASE
SPECIFY YOUR
MODEL NUMBER**



1455 KLEPPE LANE
SPARKS, NEVADA

BACHWEG 3
CH3401 BURGDORF
SWITZERLAND

DRAWN BY: P. MCMULLEN	DATE: 08/02/99	CHECK BY:	APP'D BY:	SCALE: 1/5
TITLE: 1001MS/1001HPSMS			PART NUMBER: 0002076510	
DRAWING TYPE: PARTS BREAKDOWN			DRAWING NUMBER: 14222C00	REV: 5

NOTES:

1. HOLD ROUGH-IN DIMENSIONS ± 1/8" (3.2mm).
2. WHEN INSTALLING THIS UNIT, LOCAL, STATE, OR FEDERAL CODES SHOULD BE ADHERED TO FOR INSTALLATION DIMENSIONS (LOCATIONS), WASTE AND SUPPLY REQUIREMENTS OTHER THAN SHOWN.
3. ** INSTALLER MUST PROVIDE TRAP FOR PROPER INSTALLATION.

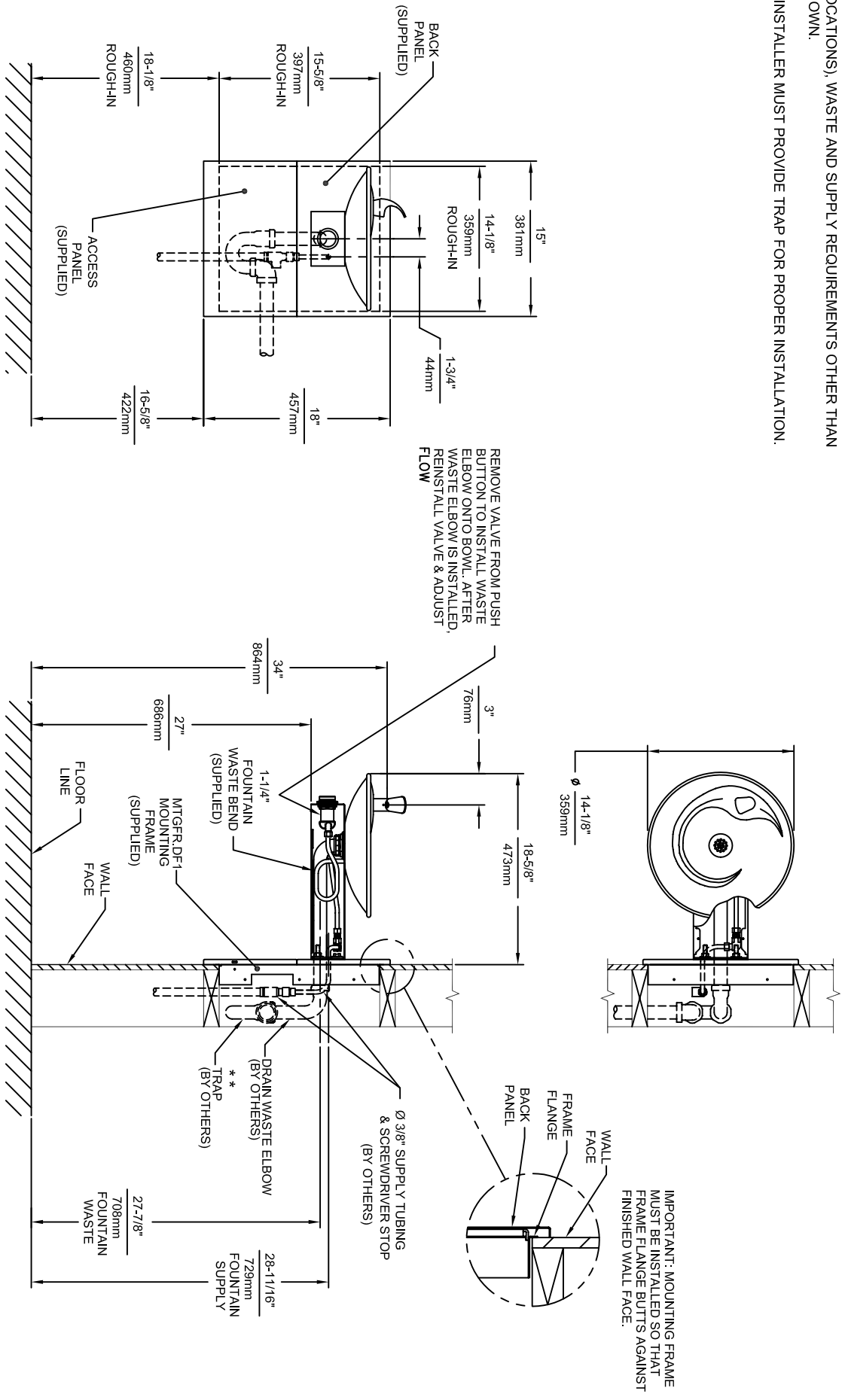

©2006 Haws Corporation - All Rights Reserved

HAWSS® and other trademarks used in these materials are the exclusive property of Haws Corporation.

INFO FAX : 1-888-FAX-HAWS (1-888-329-4297)

1455 Kiappa Ln, Sparks NV, 89431
 Phone: 775-359-4712 Fax: 775-359-7424
 Haws Ag Building 3 CH-3401 Burgdorf Switzerland and
 Haws King Pte Ltd 74 Sungai Kodut Loop Singapore 729531
 e-mail: Haws@hawsco.com website: www.hawsco.com

ORDER NO.	1001MS/1001HPSMS	MODEL(S)	1001MS/1001HPSMS
DATE	8/02/99	INFO FAX DOC #	2100167/2100147767
APPROVER		SCALE	1:1
REV	8/02/99	BRAND TYPE	INSTALLATION/FABRICATION

CC 0207/6510 D
 14221A00 5
 SIZE A SH 1 OF 1