

1011MS

Wall Mounted Drinking Fountain



FEATURES & BENEFITS

Back Panel

Stainless steel back panel helps to protect the wall from inadvertent splashing, and its decorative satin finish increases location visibility and completes the fountains attractive appearance.

Finish

Beautiful #4 satin stainless steel finish basin can be easily cleaned and maintained while also resisting corrosion.

Quality Control

Both fountains are pre-built and fully water and pressure tested to ensure no leaks and proper function for reduced installation time and added peace of mind.

Construction

18 gauge Type 304 Stainless Steel fountain with attractive and functional swirl bowl design, along with a vandal-resistant bottom plate provides a long lasting unit with added peace of mind.

Bubbler Head

Polished chrome-plated brass bubbler head with integral laminar flow prevents splashing and provides a superior flow pattern. The integral basin shank and inserted roll pin adds vandal resistance strength to the design, and the shielded angled stream orifice produces a steady sanitary source of water.

Mounting

Galvanized frame and 10 gauge surface plate provide the maximum mounting strength for the 'Hi-Lo' MS style Haws drinking fountains.

Push Button

With its patented (Pat.# 6,981,692) push-button valve assembly which allows for front access stream adjustment as well as cartridge and strainer access, this fountain offers the ultimate in ease of maintenance.



SPECIFICATIONS

Model 1011MS "Hi-Lo" wall mounted barrier-free drinking fountain shall include dual 18 gauge Type 304 Stainless Steel satin finish basins with integral swirl design, push-button operated valves with front-accessible cartridge and flow adjustment, polished chrome-plated brass vandal-resistant bubbler heads with integral laminar anti-squirt flow, chrome-plated brass vandal-resistant waste strainers, vandal-resistant bottom plates, stainless steel satin finish back and access panels allowing for front access of P-trap and stop, in-wall mounting frame, high and low fountain mounting levels, and 1-1/4" O.D. waste pipes.

OPTIONS

- Bubbler Head: Model 5725 EnviroGard™ bubbler is a polished chrome-plated solid brass bubbler head with stainless steel water activated pop up canopy. (Pat.# 7,025,282)
- Filter: Model 6426, 12" x 2", in-line lead removal element that reduces lead from incoming water supply.
- Cane Touch Skirt: Model SK3, satin finish stainless steel cane touch skirt for installation on high unit to comply with ADA protruding objects guidelines.
- Chiller: Model HCR8, chiller provides for instantaneous cooling to meet a continuous demand for chilled water.

To see all options for this model, visit www.hawsc.com.

APPLICATIONS

Perfect for either public or private indoor/outdoor settings, Model 1011MS is a great fit in areas where aesthetics are important to the overall appeal of the architecture. This series is precisely mounted, making it a nice addition to any surrounding. Beautiful satin finish helps to maintain the fountains overall appeal so it always remains looking as new as it did when it was installed. Specifically, this type of wall mounted drinking fountain may be placed in settings such as: schools and other locations in and around office buildings where the temperature remains above freezing.

Model meets all current Federal Regulations for the disabled including those in the Americans with Disabilities Act. Haws manufactures drinking fountains, electric water coolers and electric drinking fountains to be lead-free by all known definitions including ANSI/NSF Standard 61, Section 9, California Proposition 65, and the Federal Safe Drinking Water Act.



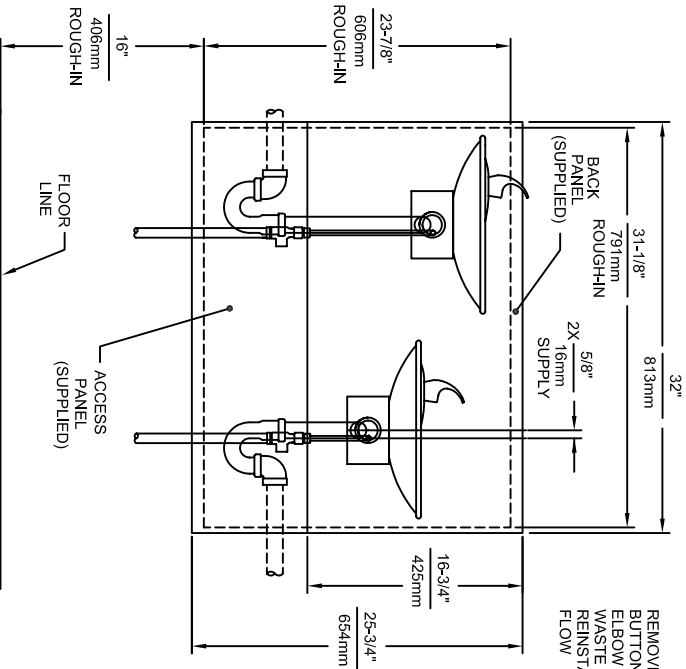
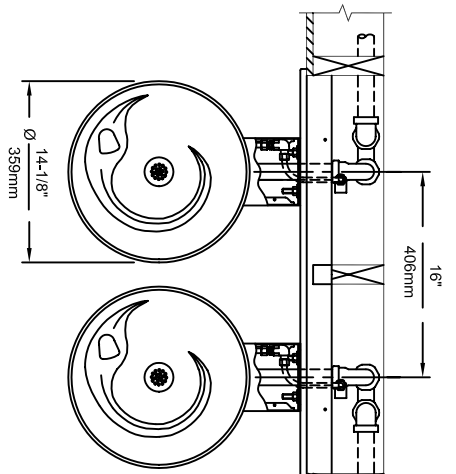

REMOVE VALVE FROM PUSH BUTTON TO INSTALL WASTE ELBOW ONTO BOWL. AFTER WASTE ELBOW IS INSTALLED, REINSTALL VALVE & ADJUST FLOW

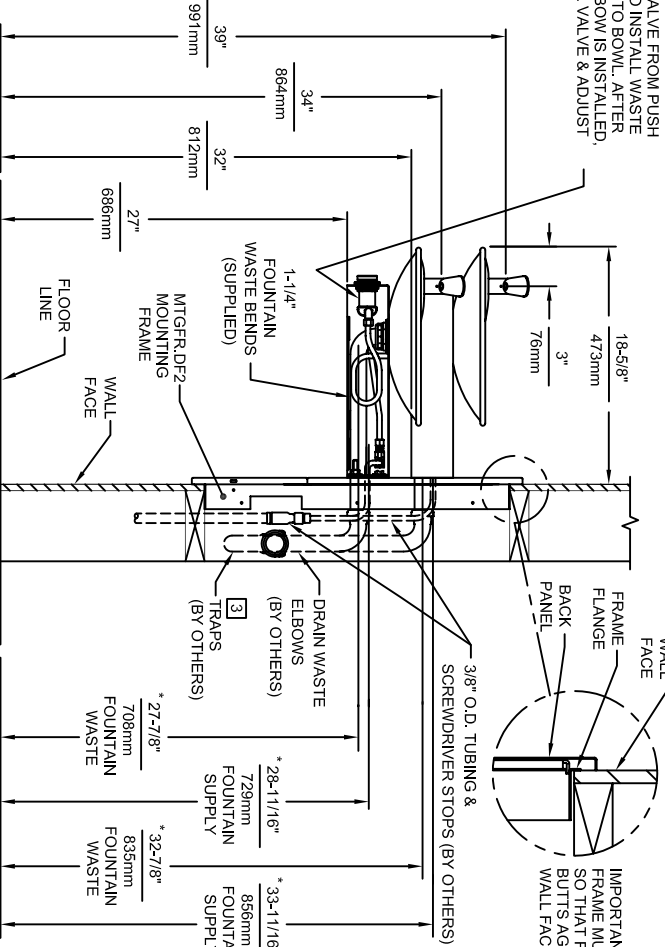

IMPORTANT: MOUNTING FRAME MUST BE INSTALLED SO THAT FRAME FLANGE BACK PANEL IS AGAINST FINISHED WALL FACE.

- NOTES:**
1. HOLD ROUGH-IN DIMENSIONS $\pm 1/8"$ (3.2mm).
 2. WHEN INSTALLING THIS UNIT, LOCAL, STATE, OR FEDERAL CODES SHOULD BE ADHERED TO FOR DIMENSIONS (LOCATIONS), WASTE AND SUPPLY REQUIREMENTS OTHER THAN SHOWN.
 3. INSTALLER MUST PROVIDE TRAP FOR PROPER INSTALLATION.

4. HOLE COMBINATION SHOWN BELOW IS FOR USE WITH LOW FOUNTAIN ON THE RIGHT AND HIGH FOUNTAIN ON THE LEFT. USE OPPOSITE HOLES FOR HIGH ON RIGHT AND LOW ON LEFT.
5. TO CHANGE FOUNTAIN MTG. SCREW LOCATIONS: FIRST REMOVE SCREWS AND THEN SQUEEZE CLIPS ON NUT RETAINER TO POP OUT. SNAP INTO NEW POSITIONS FROM BACKSIDE AND RE-ASSEMBLE SCREWS.
6. IMPORTANT: A L.H. LOW (OPTIONAL) CONFIGURATION WILL REQUIRE A DIFFERENT BACK PANEL AND THE WASTE AND SUPPLY DIMENSIONS SHOWN (?) MUST BE REVERSED.

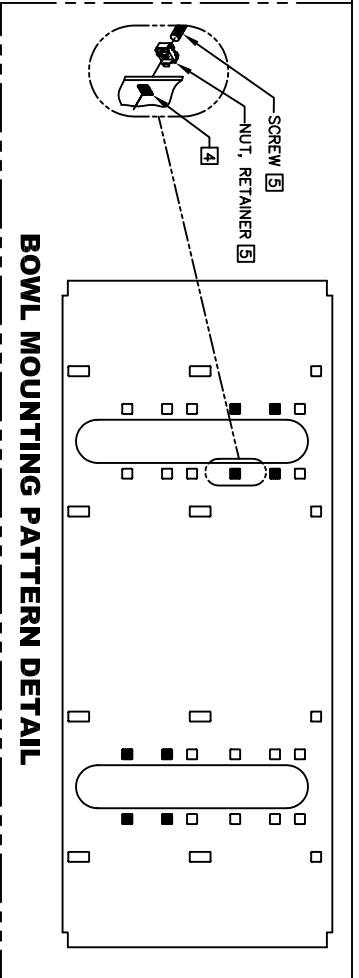

Haws Corporation

INFO FAX : 1-888-FAX-HAWS (1-888-329-4297)

1455 Kiappa Ln, Sparks NV, 89431
 Phone: 775-359-4712 Fax: 775-359-7424
 Haws Ag Bichweg 3 CH-3401 Burgdorf Switzerland
 Haws Mfg Pte Ltd 74 Sungai Kodut Loop Singapore 729531
 e-mail: Haws@hawsco.com Website: www.hawsco.com

REG. NO. 1011HPSMS/1011MS
 DATE: 08/02/99
 CHECKED: []
 APPROVED: []
 SCALE: 1:15
 DRAWING TYPE: INSTALLATION/FAZBACK

MODEL(S): 1011HPSMS/1011MS
 INFO FAX DOC # 21011467/2101167

DATE: 08/02/99
 CHECKED: []
 APPROVED: []
 SCALE: 1:15
 DRAWING TYPE: INSTALLATION/FAZBACK

SIZE: A 1 SHEET 1 OF 1



INSTALLATION, OPERATION & MAINTENANCE INSTRUCTIONS

1455 Kleppe Lane ♦ Sparks, NV 89431-6467 ♦ (775) 359-4712 ♦ Fax (775) 359-7424
HAWS AG ♦ Bachweg 3 ♦ CH-3401 Burgdorf ♦ Switzerland
Haws Mfg. Pte Lt. ♦ 2A Sungei Kadet Drive ♦ Singapore 729554
Avlis-Avenida Senador, Testonio Vilela ♦ 505 Jardim Aeroporto ♦ Itu, S.P. 13304-550 ♦ Brasil
E-mail: haws@hawsco.com ♦ website: www.hawsco.com

No. 2076519(6)

Model 1011HPSMS/1011MS Drinking Fountain

NOTE TO INSTALLER: Please leave this information with the Maintenance Department.

LIMITED WARRANTY

HAWS® warrants that all of its products are guaranteed against defective material or poor workmanship for a period of **one year from date of shipment**. HAWS liability under this warranty shall be discharged by furnishing without charge F.O.B. HAWS Factory any goods, or part thereof, which shall appear to the Company upon inspection to be of defective material or not of first class workmanship, provided that claim is made in writing to company within a reasonable period after receipt of the product. Where claims for defects are made, the defective part or parts shall be delivered to the Company, prepaid, for inspection. HAWS will not be liable for the cost of repairs, alterations or replacements, or for any expense connected therewith made by the owner or his agents, except upon written authority from HAWS, Sparks, Nevada. HAWS will not be liable for any damages caused by defective materials or poor workmanship, except for replacements, as provided above. Buyer agrees that Haws has made no other warranties either expressed or implied in addition to those above stated, except that of title with respect to any of the products or equipment sold hereunder and that HAWS shall not be liable for general, special, or consequential damages claimed to arise under the contract of sale. The drinking fountain manufactured by HAWS is warranted to function if installation and maintenance instructions provided are adhered to. The units also must be used for the purpose for which they were intended.

NO OTHER WARRANTIES EXPRESSED OR IMPLIED ARE AUTHORIZED, PROVIDED OR GIVEN BY HAWS.

SHOULD YOU EXPERIENCE DIFFICULTY WITH THE INSTALLATION OF THIS MODEL, PLEASE CALL:

1-800-766-5612

FOR PARTS CALL:

1-800-758-9378

**(U.S.A. AND CANADA ONLY) MONDAY-THURSDAY: 6:00 A.M. – 4:00 P.M. PST
FRIDAY: 6:00 A.M – 1:00 P.M. PST**

RECOMMENDED TOOLS: Hack saw, pipe joint sealant, screwdriver, level, 12" adjustable wrench, 10" pipe wrench, 5/32" hex key wrench, 9/16", 1/2", 7/16" socket wrench or open end wrench.

LOCATION OF UNIT: When installing Model 1011HPSMS/1011MS Drinking Fountain is a wheelchair accessible drinking water facility. The height dimensions shown, meet current ADA requirements. When installing this unit, local, state or federal codes should be adhered to. If height other than shown is required, then dimensions must be adjusted accordingly.

SUPPLY LINE: The minimum recommended line size is 1/2" IPS with 30-90 psi (2-6 ATM) flowing pressure. Where sediment or mineral content is a problem, an inlet filter is recommended.

PLUMBING CONNECTIONS: Inlet is 3/8" O.D. compression fitting. Waste elbow outlet is 1-1/4" O.D. tube.

MAINTENANCE: Periodically clean the strainer. Refer to 5874 Valve Manual for more information.

TROUBLESHOOTING

| PROBLEM | REPAIR CHECKLIST |
|-------------------------------|--|
| 1. Insufficient bubbler flow. | 1a. Check that inlet screwdriver stop valve (not supplied) is wide open. b. Verify minimum 30 psi flowing supply pressure. c. Clean strainer. See 5874 Valve Manual. d. Adjust valve to increase flow. Use front adjust screw or see 5874 Valve manual. |

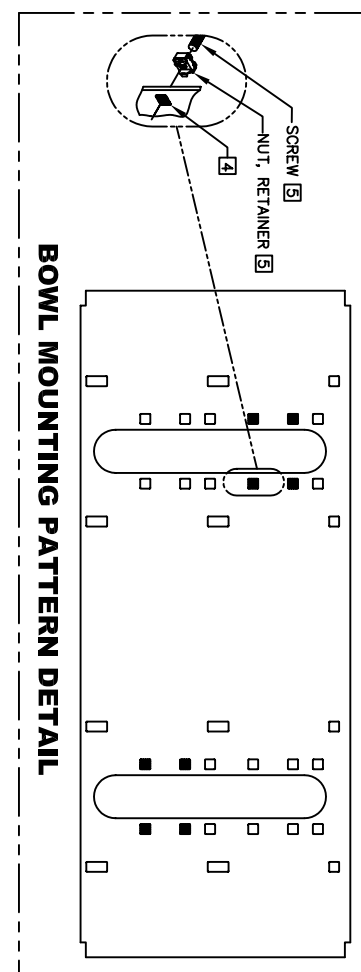
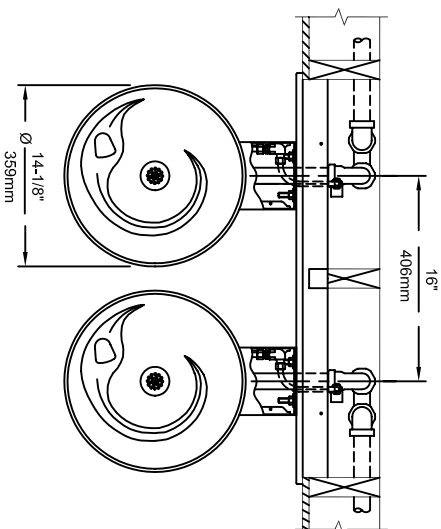

BOWL MOUNTING PATTERN DETAIL

- NOTES:**
1. HOLD ROUGH-IN DIMENSIONS $\pm 1/8"$ (3.2mm).
 2. WHEN INSTALLING THIS UNIT, LOCAL STATE OR FEDERAL CODES SHOULD BE ADHERED TO FOR DIMENSIONS (LOCATIONS), WASTE AND SUPPLY REQUIREMENTS OTHER THAN SHOWN.
 3. INSTALLER MUST PROVIDE TRAP FOR PROPER INSTALLATION.
 4. HOLE COMBINATION SHOWN BELOW IS FOR USE WITH LOW FOUNTAIN ON THE RIGHT AND HIGH FOUNTAIN ON THE LEFT. USE OPPOSITE HOLES FOR HIGH ON RIGHT AND LOW ON LEFT.
 5. TO CHANGE FOUNTAIN MTG. SCREW LOCATIONS: FIRST REMOVE SCREWS AND THEN SQUEEZE CLIPS ON NUT RETAINER TO POP OUT. SNAP INTO NEW POSITIONS FROM BACKSIDE AND RE-ASSEMBLE SCREWS.
 6. IMPORTANT: A L.H. LOW (OPTIONAL) CONFIGURATION WILL REQUIRE A DIFFERENT BACK PANEL AND THE WASTE AND SUPPLY DIMENSIONS SHOWN (?) MUST BE REVERSED.

REMOVE VALVE FROM PUSH BUTTON TO INSTALL WASTE ELBOW ONTO BOWL. AFTER WASTE ELBOW IS INSTALLED, REINSTALL VALVE & ADJUST FLOW

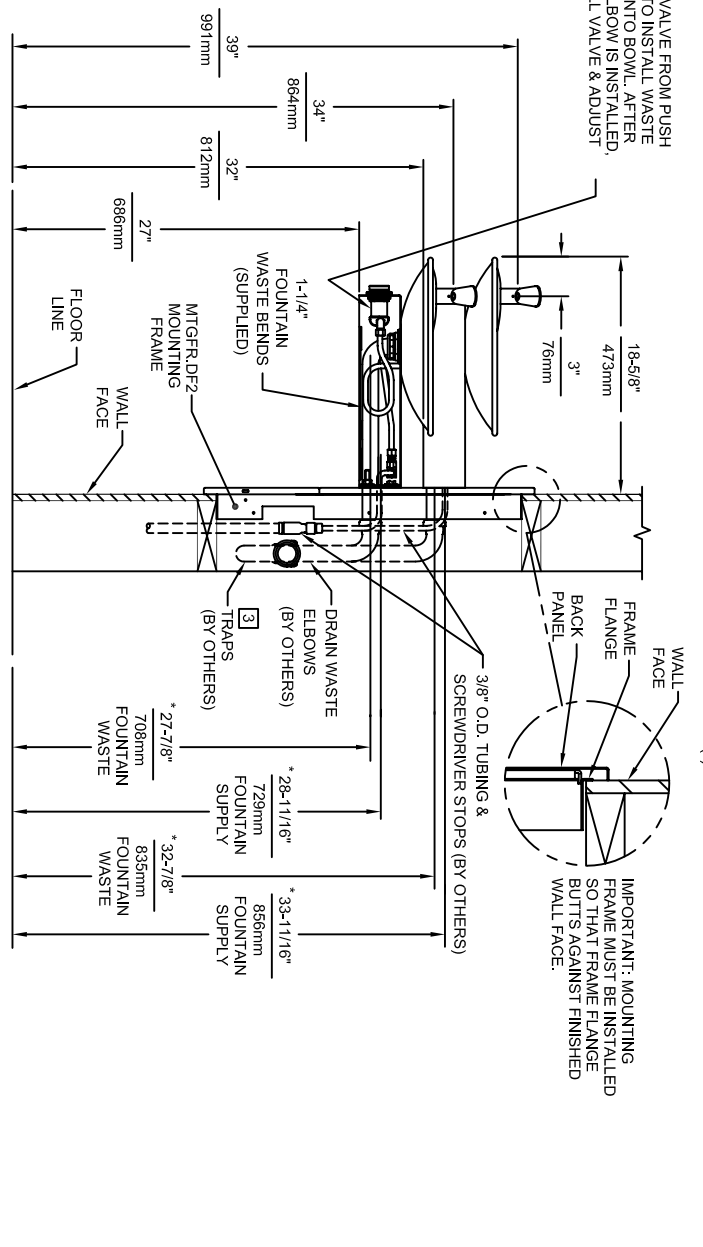
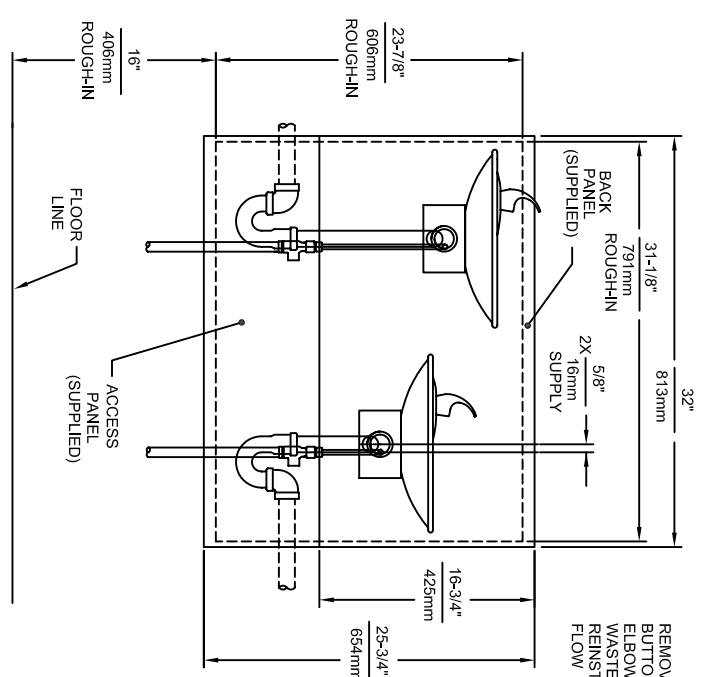

IMPORTANT: MOUNTING FRAME MUST BE INSTALLED SO THAT FRAME FLANGE BACK PANEL IS AGAINST FINISHED WALL FACE.

Haws Corporation

Phone: 775-359-4712 Fax: 775-359-7424

Haws Ag Building 3 CH-3401 Burgdorf Switzerland

Haws Ming Pte Ltd 74 Sungei Kodat Loop Singapore 729531

e-MAIL: Haws@hawsco.com Website: www.hawsco.com

REG. NO. 1011HPSMS/1011MS

DATE: 08/02/99

SCALE: 1:16

INFO FAX DOC # 21011467/2101167

FORMING TYPE: INSTALLATION/FABRICATION

REG. NO. 1011HPSMS/1011MS

DATE: 08/02/99

SCALE: 1:16

INFO FAX DOC # 21011467/2101167

FORMING TYPE: INSTALLATION/FABRICATION

REG. NO. 1011HPSMS/1011MS

DATE: 08/02/99

SCALE: 1:16

INFO FAX DOC # 21011467/2101167

FORMING TYPE: INSTALLATION/FABRICATION

PARTS BREAKDOWN

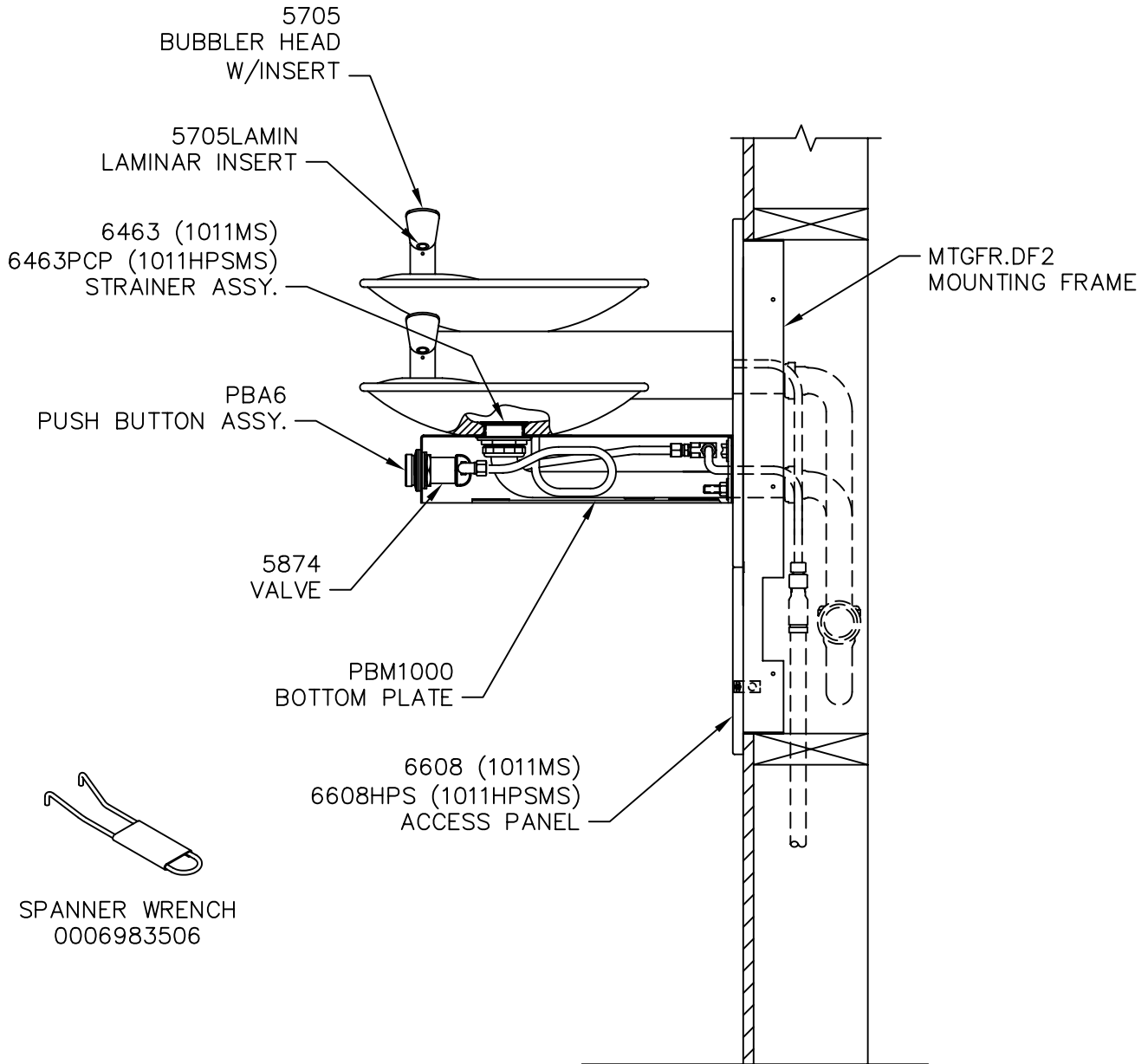

**WHEN ORDERING
PARTS PLEASE
SPECIFY YOUR
MODEL NUMBER**



1455 KLEPPE LANE
SPARKS, NEVADA

BACHWEG 3
CH3401 BURGDORF
SWITZERLAND

| | | | | |
|----------------------------------|----------------|-----------|-----------------------------|------------|
| DRAWN BY: P MCMULLEN | DATE: 08/02/99 | CHECK BY: | APP'D BY: | SCALE: 1/4 |
| TITLE: 1011HPSMS/1011MS | | | PART NUMBER: 0002076519 | |
| DRAWING TYPE: PARTS BREAKDOWN | | | DRAWING NUMBER: 14220C00 | REV: 6 |