

H1011.8HPS

Barrier-Free Wall Mounted Electric Drinking Fountain



FEATURES & BENEFITS

Back Panel

Stainless steel back panel helps to protect the wall from inadvertent splashing, and its decorative satin finish increases location visibility and completes the fountains attractive appearance.

Barrier-Free

Barrier-free capabilities combined with its ease of use allows for a number of installation location possibilities.

Quality Control

Both fountains are pre-built and fully water and pressure tested to ensure no leaks and proper function for reduced installation time and added peace of mind.

Construction

18 gauge Type 304 Stainless Steel fountain with attractive and functional swirl bowl design, along with a vandal-resistant bottom plate provides a long lasting unit with added peace of mind.

Bubbler Head

Polished chrome-plated brass bubbler head with integral laminar flow prevents splashing and provides a superior flow pattern. The integral basin shank and inserted roll pin adds vandal resistance strength to the design, and the shielded angled stream orifice produces a steady sanitary source of water.

Mounting

Heavy-duty galvanized steel mounting frame provides the sturdy hidden support needed for the "Hi-Lo" configuration of this unit. Further convenience is given to the chiller with the integral fold-out shelf.

Push Button

With its patented (Pat.# 6,981,692) push-button valve assembly which allows for front access stream adjustment as well as cartridge and strainer access, this fountain offers the ultimate in ease of maintenance.



SPECIFICATIONS

Model H1011.8HPS "Hi-Lo" electric wall mounted barrier-free drinking fountain shall include dual 18 gauge Type 304 polished stainless steel finish basins with integral swirl design, push-button operated valves with front-accessible cartridge and flow adjustment, polished chrome-plated brass vandal-resistant bubbler heads with integral laminar anti-squirt flow, chrome-plated brass vandal-resistant waste strainers, vandal-resistant bottom plates, polished stainless steel finish back panel and louvered intrusion-proof grill, high and low fountain mounting levels, and 1-1/4" O.D. waste pipe. The R-134a refrigeration system is hermetically sealed and delivers a minimum of 8 gph (30.3 lph) of water at 50°F (10°C) cooled from 80°F (26.7°C) inlet water at 90°F (32.2°C) ambient. 115 Volts, 60Hz, rated watts: 370, full load amps: 5.

OPTIONS

- Filter: Model 6426, 12" x 2", in-line lead removal element that reduces lead from incoming water supply.

APPLICATIONS

Perfect for either public or private settings, our stainless steel electric drinking fountains are a great fit in indoor environments. This series is precisely mounted, making it a nice addition to any surrounding. Specifically, this type fountain may be placed in settings such as: schools, office buildings, shopping malls, and other indoor environments where there is a demand for a chilled water source and/or wheel chair access.

Model meets all current Federal Regulations for the disabled including those in the Americans with Disabilities Act. Electric water coolers are not recommended or designed for outdoor applications or enclosed pool areas (chlorine). These conditions may void warranty. Haws manufactures drinking fountains, electric water coolers and electric drinking fountains to be lead-free by all known definitions including ANSI/NSF Standard 61, Section 9, California Proposition 65, and the Federal Safe Drinking Water Act. Haws electric water coolers comply with ARI Standard 1010 and ANSI A117.1, and be listed by Underwriter Laboratories to U.S. and Canadian standards.



NOTES:

1. HOLD ROUGH-IN DIMENSIONS $\pm 1/8"$ (3.2mm).
2. WHEN INSTALLING THIS UNIT, LOCAL, STATE, OR FEDERAL CODES SHOULD BE ADHERED TO. FOR DIMENSIONS (LOCATIONS), WASTE AND SUPPLY REQUIREMENTS OTHER THAN SHOWN, DIMENSIONS MARKED (*) MUST BE ADJUSTED ACCORDINGLY.
3. INSTALLER MUST PROVIDE TRAP FOR PROPER INSTALLATION.
4. REFER TO 5874/ARK5874 OPERATION AND MAINTENANCE MANUAL FOR PUSH BUTTON AND VALVE INSTALLATION/MAINTENANCE INSTRUCTIONS.
5. REFER TO MTGR-18 INSTALLATION DRAWING FOR ROUGH-IN DIMENSIONS.
6. INSERT 5/16"-18 PANEL INSERTS FROM OPPOSITE SIDE AT LOCATIONS SHOWN BY DARKENED HOLES. HOLE COMBINATIONS SHOWN ARE FOR USE WITH LOW FOUNTAIN ON THE RIGHT AND THE HI FOUNTAIN ON THE LEFT. USE OPPOSITE HOLES FOR HI ON RIGHT AND LOW ON LEFT.
7. HOLE COMBINATION SHOWN BELOW IS FOR USE WITH LOW FOUNTAIN ON THE RIGHT AND HIGH FOUNTAIN ON THE LEFT. USE OPPOSITE HOLES FOR HIGH ON RIGHT AND LOW ON LEFT.
8. TO CHANGE FOUNTAIN MTG. SCREW LOCATIONS: FIRST REMOVE SCREWS AND THEN SQUEEZE CLIPS ON NUT RETAINER TO POP OUT. SNAP INTO NEW POSITIONS AND RE-ASSEMBLE SCREWS.
9. IMPORTANT: A L.H. LOW (OPTIONAL) CONFIGURATION WILL REQUIRE A DIFFERENT BACK PANEL AND THE WASTE AND SUPPLY DIMENSIONS SHOWN (*) MUST BE REVERSED.
10. ALIGN HOLES IN CHILLER SUPPORT TRAY WITH HOLES IN FRAME AND FASTEN WITH #10 SHEET METAL SCREWS.

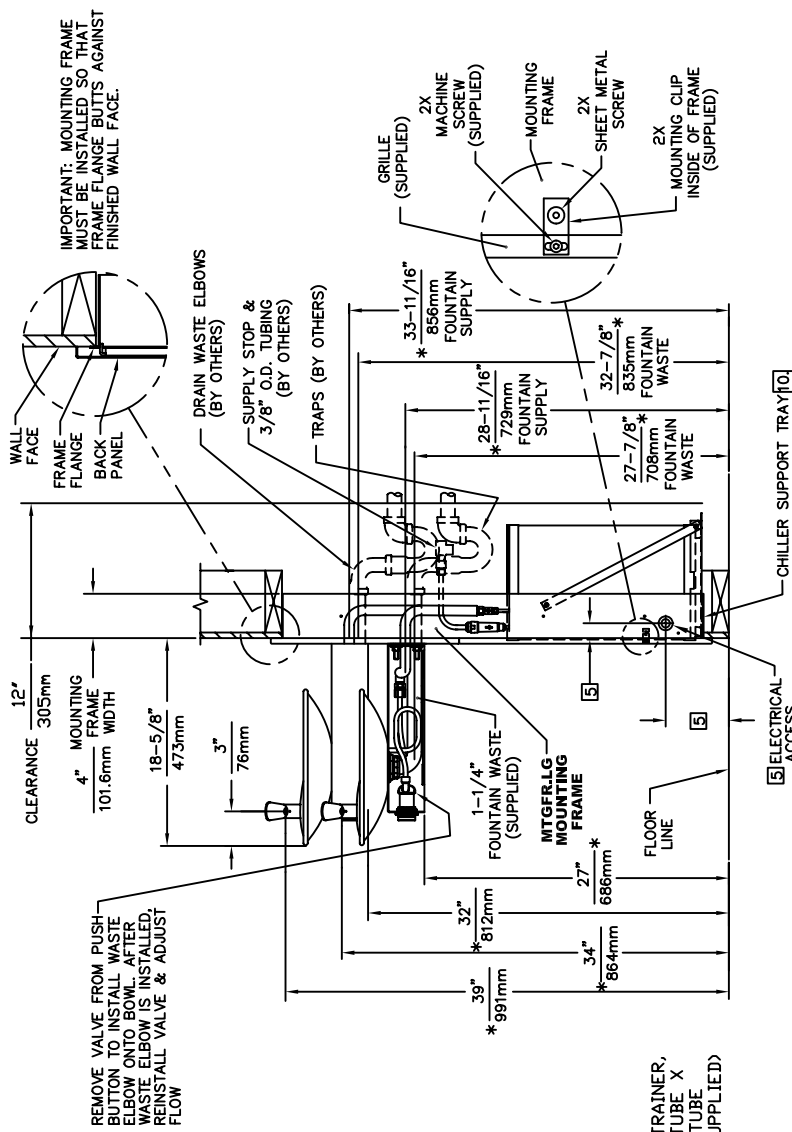
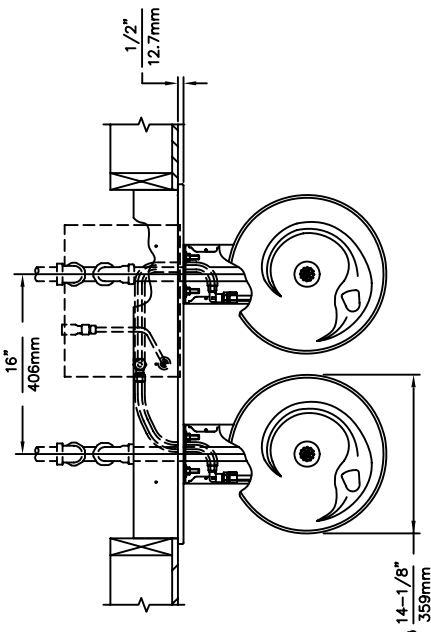

REMOVE VALVE FROM PUSH-BUTTON TO INSTALL WASTE ELBOW ONTO BOWL. AFTER WASTE ELBOW IS INSTALLED, REINSTALL VALVE & ADJUST FLOW

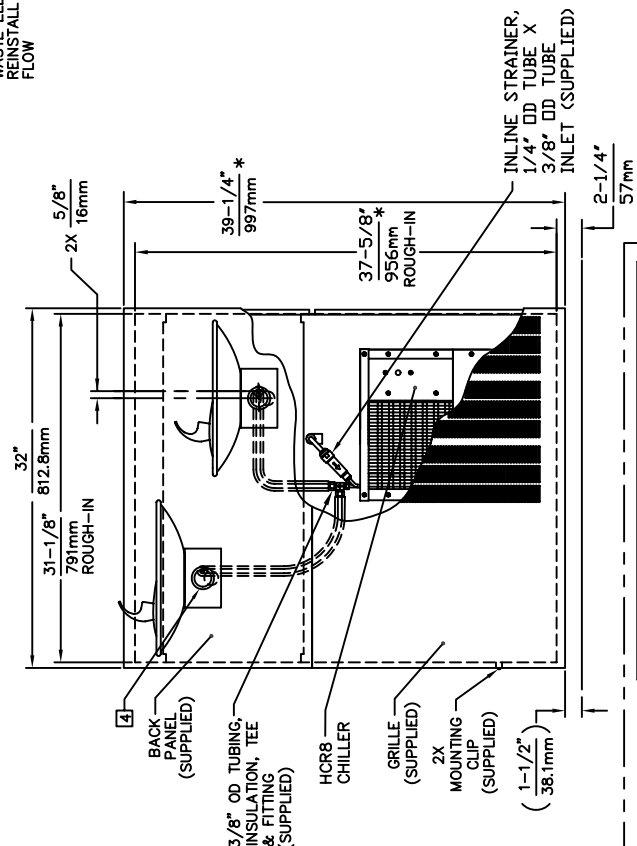

Haws Corporation

INFO FAX : 1-888-FAX-HAWS (1-888-329-4297)
 1455 Kleppe Ln, Sparks NV, 89431
 Phone: 775-359-4712 Fax: 775-359-7424
 Haws Ag Bachweg 3 CH-3401 Burgdorf Switzerland
 Haws Mfg Pte Ltd 74 Sungai Kadut Loop Singapore 729531
 e-mail: Haws@hawsco.com website: www.hawsco.com

PART NUMBER: 0002080249.D
 DRAWING NUMBER: 13135A00
 REV: 14
 SIZE: A SHT. 1 OF 1

SCALE: 1:18 DRAWING TYPE: INSTALLATION/FABRICK

REVISIONS:

REV. NO.	REVISION	BY	DATE
1	REVISED PER ELEC-4181	PKM	07/97
2	REVISED PER RTM	PKM	07/97

APPROVER: [Signature]

MODEL(S): H1011.8/H1011.8HPS

BOWL MOUNTING PATTERN DETAIL



INSTALLATION, OPERATION & MAINTENANCE INSTRUCTIONS

1455 Kleppe Lane ♦ Sparks, NV 89431-6467 ♦ (775) 359-4712 ♦ Fax (775) 359-7424
HAWS AG ♦ Bachweg 3 ♦ CH-3401 Burgdorf ♦ Switzerland
Haws Mfg. Pte Lt. ♦ 2A Sungei Kadet Drive ♦ Singapore 729554
Avlis-Avenida Senador, Testonio Vilela ♦ 505 Jardim Aeroporto ♦ Itu, S.P. 13304-550 ♦ Brasil
E-mail: haws@hawsco.com ♦ website: www.hawsco.com

No. 2080249(14)

Model H1011.8/H1011.8HPS Water Cooler

NOTE TO INSTALLER: Please leave this information with the Maintenance Department.

A ground-fault circuit breaker shall be installed in the branch circuit supplying fountain equipment. NEC680-51(a).

CAUTION! Prior to making any electrical connections, verify with a voltmeter that power from the service panel is **off**.

LIMITED WARRANTY

HAWS® warrants that all of its products are guaranteed against defective material or poor workmanship for a period of **one year from date of shipment**. HAWS liability under this warranty shall be discharged by furnishing without charge F.O.B. HAWS Factory any goods, or part thereof, which shall appear to the Company upon inspection to be of defective material or not of first class workmanship, provided that claim is made in writing to company within a reasonable period after receipt of the product. Where claims for defects are made, the defective part or parts shall be delivered to the Company, prepaid, for inspection. HAWS will not be liable for the cost of repairs, alterations or replacements, or for any expense connected therewith made by the owner or his agents, except upon written authority from HAWS, Sparks, Nevada. HAWS will not be liable for any damages caused by defective materials or poor workmanship, except for replacements, as provided above. Buyer agrees that Haws has made no other warranties either expressed or implied in addition to those above stated, except that of title with respect to any of the products or equipment sold hereunder and that HAWS shall not be liable for general, special, or consequential damages claimed to arise under the contract of sale. The drinking fountain manufactured by HAWS is warranted to function if installation and maintenance instructions provided are adhered to. The units also must be used for the purpose for which they were intended.

NO OTHER WARRANTIES EXPRESSED OR IMPLIED ARE AUTHORIZED, PROVIDED OR GIVEN BY HAWS.

SHOULD YOU EXPERIENCE DIFFICULTY WITH THE INSTALLATION OF THIS MODEL, PLEASE CALL:

1-800-766-5612

FOR PARTS CALL:

1-800-758-9378

**(U.S.A. AND CANADA ONLY) MONDAY-THURSDAY: 6:00 A.M. – 4:00 P.M. PST
FRIDAY: 6:00 A.M – 1:00 P.M. PST**

RECOMMENDED TOOLS: Hack saw, pipe joint sealant, screwdriver, level, 12" adjustable wrench, 10" pipe wrench, 3/32" and 5/32 " hex key wrench, 9/16", 1/2", 7/16" socket wrench or open end wrench.

LOCATION OF UNIT: The Model H1011.8/H1011.8HPS Cooler is a wheelchair accessible drinking facility. The height dimensions shown, meet current ADA requirements. When installing this unit, local, state or federal codes should be adhered to. If height other than shown is required, then dimensions must be adjusted accordingly.

SUPPLY LINE: The minimum recommended line size is 1/2"IPS with 30-90 psi (2-6 ATM) flowing pressure. Where sediment or mineral content is a problem, an inlet filter is recommended.

PLUMBING CONNECTIONS: Inlet is 3/8" O.D. tube. Waste elbow outlet is 1-1/4" O.D. tube.

ELECTRICAL CONNECTIONS: 115VAC, 60HZ, 4.7 AMPS. Chiller wired direct to incoming line, by others.

PARTS LIST		
MODEL PACKAGE	QUANTITY	ITEMS INCLUDED
MTGFR.LG	1	Mounting Frame
	3	#10 Sheet Metal Screws
HCR8	1	Chiller
H1011.8/H1011.8HPS	2	Bowl Assembly with push button valve
	1	Package supply tubing assembly with strainer, tubes and fittings
	1	Panel-bowl back
	1	Grille
	1	Package of two each-grille attachment clips, clip nuts, #10 sheet metal screws and 6-32 screws.
	2	Waste Elbow 1-1/4" O.D.
	8	5/16-18 retainer nuts
	8	5/16-18 x 1 hex head screws

INSTALLATION PROCEDURE

GENERAL NOTES:

The Model H1011.8/H1011.8HPS Water Cooler assembly requires installation of the mounting frame as described in Steps 1 - 2, then mounting the fountain bowl assembly as described in Steps 3 - 6, and finally completing chiller water and electrical connections and starting chiller per Steps 7 - 11. First check that all required parts are received.

Grounding may cause electrical feedback into the electric drinking fountain causing an electrolysis, which creates a metallic taste or an increase in the metal content of the water. This condition can be avoided by using dielectric couplings in the assembly. The waste line, which is supplied by the installer, should also have a dielectric (plastic) coupling to completely isolate the assembly from the building plumbing system.

For all plastic push-in type fitting connections; push tubing into fitting until it bottoms out to ensure a watertight connection. To remove, depress collet and pull tubing out.

INSTALLATION PROCEDURE...

- Step 1:** Provide wall opening as detailed in Installation Drawing. Frame must be positioned such that frame flanges overlap and butt against finished wall surface. Mounting holes are provided for #6 sheet metal screws. After frame is positioned in wall, swing chiller support tray into position (See Installation Drawing), align tray holes with holes in frame and fasten with #10 sheet metal screws. Mounted frame must support 50 pound chiller in addition to fountain weight and user generated forces.
- Step 2:** Install waste, supply and electrical lines in locations shown in Installation Drawing. Waste and supply lines may be installed for either rear or side entry. Verify proper waste, supply, electrical and frame locations. Use level to verify horizontal and vertical frame mounting to insure proper bowl drainage.
- Step 3:** Installation Drawing shows fountain bowls, back panel and grille locations. Unpack bowls and remove bottom plate using 3/32" hex allen wrench. Install back panel on frame with narrower edge to bottom. Position nut retainers into mounting frame and use two 5/16-18x1 hex head screws partially started in outside holes to support panel. Install bowl/bracket assembly onto panel using eight 5/16-18x1 hex head screws hand tightened. See sheet 2 of Installation Drawing for appropriate bowl mounting pattern to use for this model.
- Step 4:** Remove 1-1/2" IPS outlet elbow from traps (not supplied). Install elbow inside frame onto waste stub-outs. Reassemble trap "U" bends with inlets centered behind fountains.
- Step 5:** Remove slip joint nuts from bottom of fountain waste outlets. Assemble nut over 1-1/4 O.D. end of longer waste elbow as supplied by Haws. Assemble waste elbows onto bowl waste body using seal washer provided and tighten nut hand tight. Measure vertical distance down to trap inlets and cut the vertical elbow (not supplied) to length allowing 1/2" minimum for engagement into trap. Mark and similarly cut to length the horizontal waste elbow. Install elbows and tighten slip joint nuts.
- Step 6:** See Figure 1 for detail section view of side screw grille attachment. Unpack grille and insert upper lip behind bottom of back panel, align sides and hold up flush to bottom of back panel. Hold grille against wall and mark centers of grille side slots on wall. Masking tape may be used to prevent finished wall damage from mark. Install the "s" clips in mounting frame using #10 sheet metal screws into pre-drilled holes on lower end of each side of frame. Tighten #10 screw while holding "s" clips centered on wall marks. Check grille fit by installing grille and partially tightening #6-23 socket head screws through side of grille. Insure proper panel and grille alignment, then tighten eight 5/16-18x1 hex head screws.
- Step 7:** Unpack and remove chiller from carton. Remove front panel screws and panel. Do not remove insulating putty and foam from copper tubes or Styrofoam insulation from evaporator coil. Remove any inner packing, which may be around compressor. If applicable, remove junction box cover and electrical knock out on lower right side of housing. Install fittings (supplied) on chiller inlet and outlet tubes (See Installation Drawing).

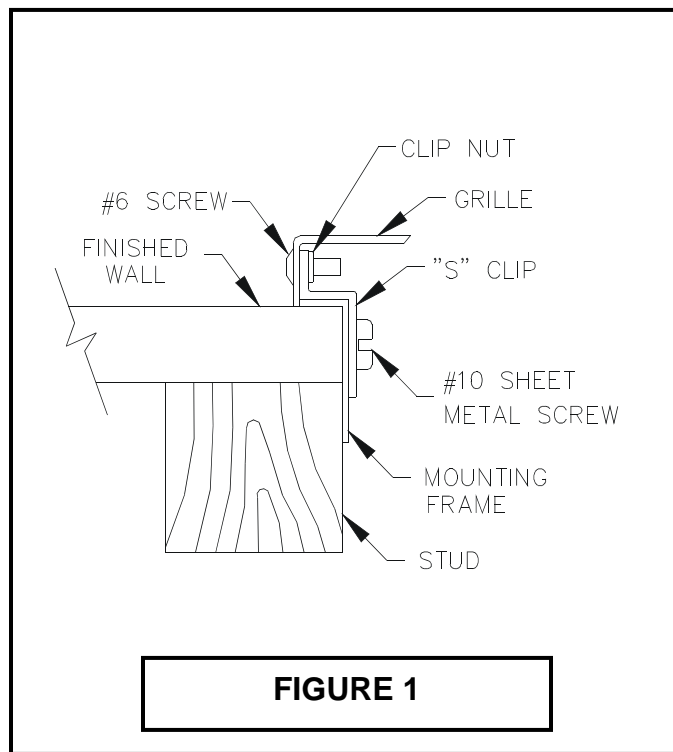

INSTALLATION PROCEDURE...

- Step 8:** Thoroughly flush supply line to remove all foreign matter. Connect 1/2" IPS supply screwdriver stop (not supplied) to stub-out in wall. Place chiller on chiller support tray against right hand side, fully to rear, with condenser (open panel) side facing to front. Install supply (3/8" O.D.) tubing (not supplied), between screwdriver stop (not supplied) and chiller inlet. (Cut tubing to proper length, and follow general notes for proper connection procedures for push-in type fittings). Tubing insulation is not normally required on inlet side of chiller. Install insulated tube (supplied) between fountain and chiller outlet. Cut tubes as required and connect to chiller outlet compression fitting. Open screwdriver stop **wide open** while checking for leaks at all connections.
- Step 9:** Adjust bubbler stream height using a small flat-head screwdriver inserted through a hole in the center of the push button for increased flow turn clockwise and for decreased flow turn counterclockwise. If flow problems arise, see troubleshooting guide for additional instructions to correct problem. Bubbler stream may lower during short break-in period. Set initial stream height a little high to minimize or eliminate the need for break-in period readjustment.
- Step 10:** Verify that electrical power is off and power supply voltage, phase and cycle match specifications printed on chiller label. In accordance with local codes, wire directly to incoming lines at internal chiller junction box. Verify that all inner packing is removed and hand rotate fan blade to verify free rotation. Reattach chiller front panel. Turn power on and verify that chiller cycles off after water reaches proper temperature. Finally, check for leaks.
- Step 11:** Install grille and tighten outer screws. Verify there is chilled water out of bubbler.

MAINTENANCE

Step 1: The condenser fins on chiller should be periodically cleaned with brush, air hose or vacuum cleaner. Care should be taken not to bend or deform the condenser fins.

Step 2: The chiller temperature control is factory set for 50° F water under normal conditions. For colder water, adjust control clockwise. For warmer water, turn counterclockwise. Remove front chiller panel for access to temperature control. After adjustment allow unit to cycle off before checking outlet water temperature.

TROUBLESHOOTING	
PROBLEM	REPAIR CHECKLIST
1. Insufficient bubbler flow.	1a. Check that inlet screwdriver stop valve is in wide-open position. b. Verify minimum 30 psi flowing supply pressure. c. Clean strainer. See 5874 Valve Manual. d. Adjust valve to increase flow. Use front adjust screw or see 5874 Valve Manual.
2. Water too warm or cold.	a. Adjust chiller temperature control, clockwise for colder water.

ITEM	MODEL		DESCRIPTION
	H1011.8	H1011.8HPS	
1	0006983506	0006983506	SPANNER WRENCH
2	5705	5705	BUBBLER HEAD W/INSERT
3	6463	6463PCP	STRAINER ASSY
4	PBA6	PBA6	PUSH BUTTON ASSY
5	5874	5874	VALVE
6	PBM1000	PBM1000	ACCESS PLATE
7	MTGFR.LG	MTGFR.LG	MOUNTING FRAME
8	HCR8	HCR8	CHILLER
9	0002626651	0002626665	GRILLE
10	0004012000	0004012023	BACK PANEL

PARTS BREAKDOWN

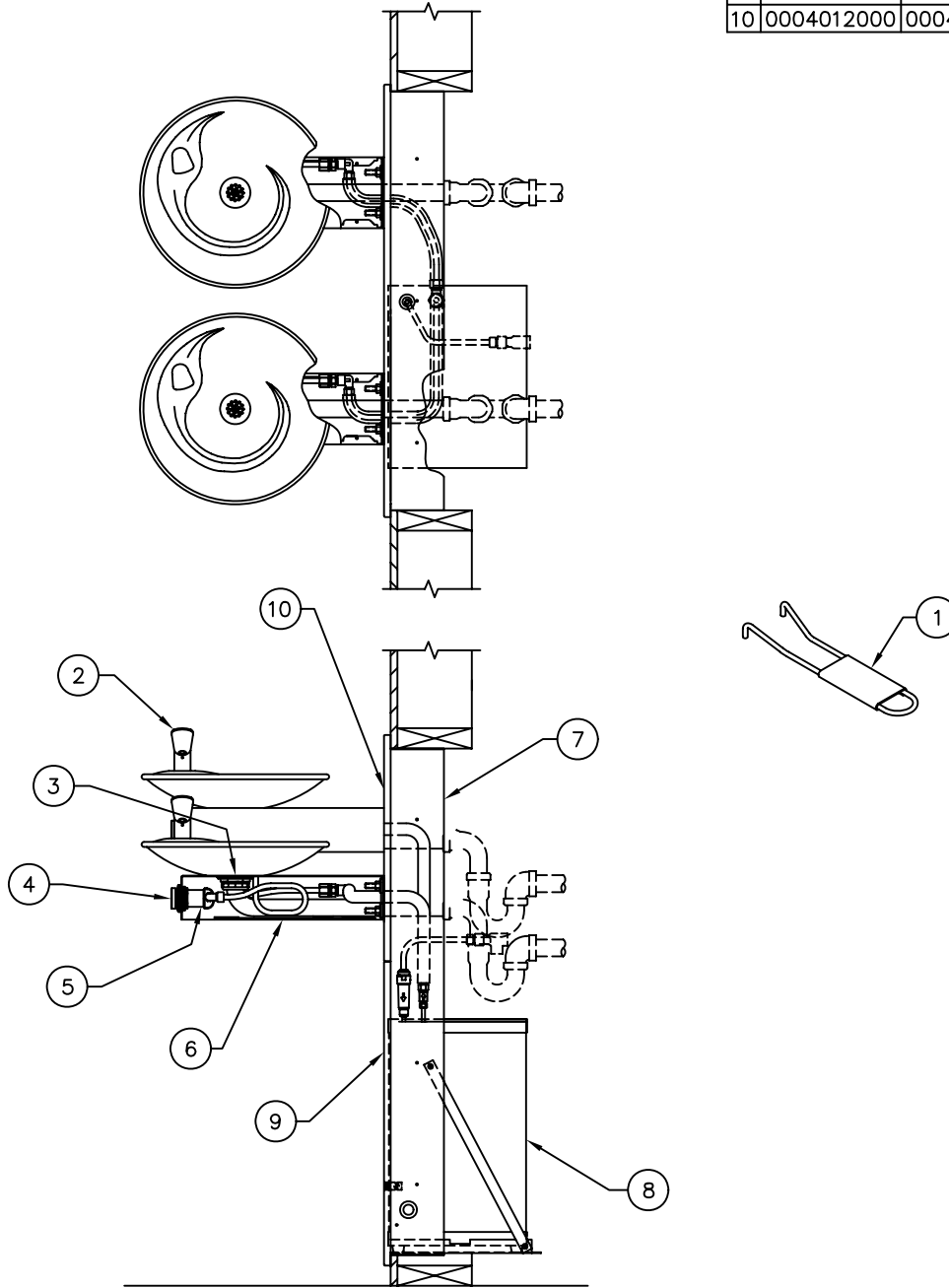

**WHEN ORDERING
PARTS PLEASE
SPECIFY YOUR
MODEL NUMBER**



1455 KLEPPE LANE BACHWEG 3
SPARKS, NEVADA CH3401 BURGDORF
SWITZERLAND

DRAWN BY: RTM	DATE: 11/21/99	CHECK BY:	APP'D BY:	SCALE: 1/7
TITLE: H1011.8/H1011.8HPS			PART NUMBER: 0002080249	
DRAWING TYPE: PARTS BREAKDOWN			DRAWING NUMBER: 13368C00	REV. 14

NOTES:

1. HOLD ROUGH-IN DIMENSIONS $\pm 1/8"$ (3.2mm).
2. WHEN INSTALLING THIS UNIT, LOCAL, STATE, OR FEDERAL CODES SHOULD BE ADHERED TO. FOR DIMENSIONS (LOCATIONS), WASTE AND SUPPLY REQUIREMENTS OTHER THAN SHOWN, DIMENSIONS MARKED (*) MUST BE ADJUSTED ACCORDINGLY.
3. INSTALLER MUST PROVIDE TRAP FOR PROPER INSTALLATION.
4. REFER TO 5874/ARK5874 OPERATION AND MAINTENANCE MANUAL FOR PUSH BUTTON AND VALVE INSTALLATION/MAINTENANCE INSTRUCTIONS.
5. REFER TO MTGR-18 INSTALLATION DRAWING FOR ROUGH-IN DIMENSIONS.
6. INSERT 5/16"-18 PANEL INSERTS FROM OPPOSITE SIDE AT LOCATIONS SHOWN BY DARKENED HOLES. HOLE COMBINATIONS SHOWN ARE FOR USE WITH LOW FOUNTAIN ON THE RIGHT AND THE HI FOUNTAIN ON THE LEFT. USE OPPOSITE HOLES FOR HI ON RIGHT AND LOW ON LEFT.
7. HOLE COMBINATION SHOWN BELOW IS FOR USE WITH LOW FOUNTAIN ON THE RIGHT AND HIGH FOUNTAIN ON THE LEFT. USE OPPOSITE HOLES FOR HIGH ON RIGHT AND LOW ON LEFT.
8. TO CHANGE FOUNTAIN MTG. SCREW LOCATIONS: FIRST REMOVE SCREWS AND THEN SQUEEZE CLIPS ON NUT RETAINER TO POP OUT. SNAP INTO NEW POSITIONS AND RE-ASSEMBLE SCREWS.
9. IMPORTANT: A L.H. LOW (OPTIONAL) CONFIGURATION WILL REQUIRE A DIFFERENT BACK PANEL AND THE WASTE AND SUPPLY DIMENSIONS SHOWN (*) MUST BE REVERSED.
10. ALIGN HOLES IN CHILLER SUPPORT TRAY WITH HOLES IN FRAME AND FASTEN WITH #10 SHEET METAL SCREWS.

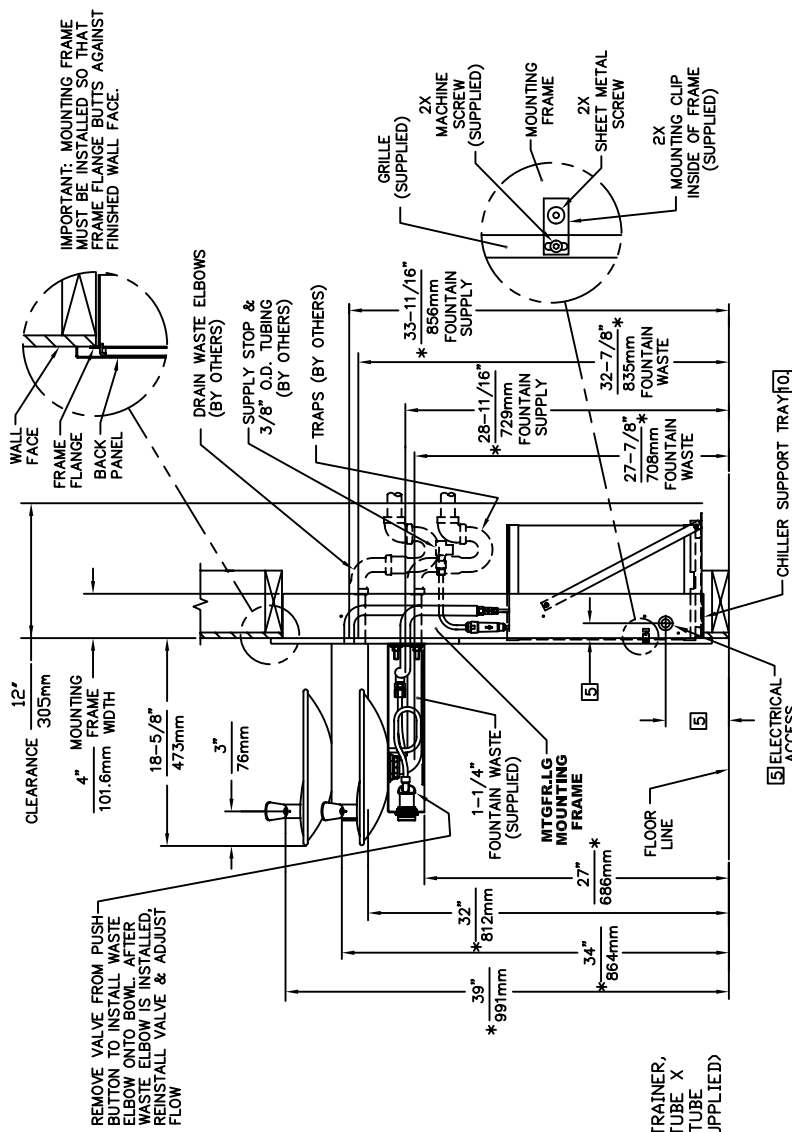
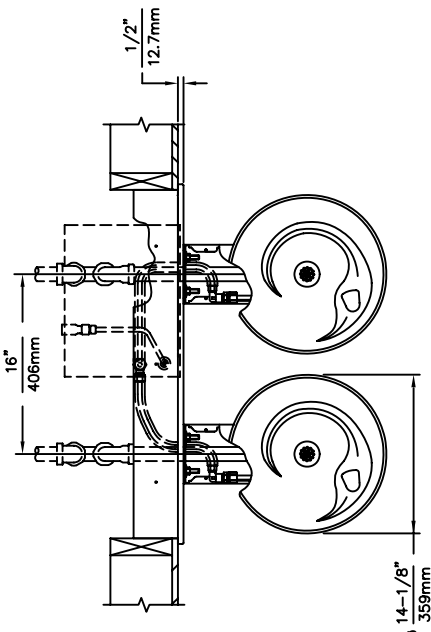

REMOVE VALVE FROM PUSH-BUTTON TO INSTALL WASTE ELBOW ONTO BOWL. AFTER WASTE ELBOW IS INSTALLED, REINSTALL VALVE & ADJUST FLOW

CHILLER SUPPORT TRAY [10]
ELECTRICAL ACCESS [5]

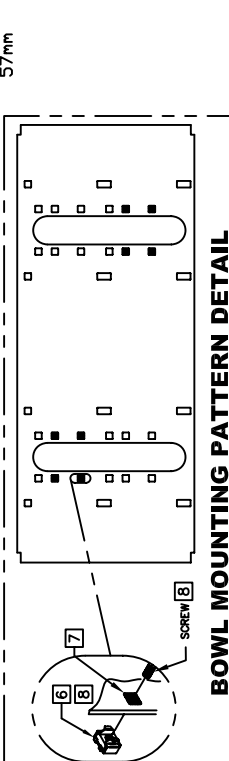

BOWL MOUNTING PATTERN DETAIL

Haws Corporation
 INFO FAX : 1-888-FAX-HAWS (1-888-329-4297)
 1455 Kieppe Ln, Sparks NV, 89431
 Phone: 775-359-4712 Fax: 775-359-7424
 Haws Ag Bachweg 3 CH-3401 Burgdorf Switzerland
 Haws Mfg Pte Ltd 74 Sungai Kadut Loop Singapore 729531
 e-mail: Haws@hawsco.com website: www.hawsco.com

REV NO. | REVISED PER | BY | DATE |
 DRAWING | ECH-4181 | PKM | 07/97 |
 APPROVER | | | |

MODEL(S): H1011.8/H1011.8HPS
 SCALE: 1:18 DRAWING TYPE: INSTALLATION/FABRICATION
 PART NUMBER: 0002080249.D
 DRAWING NUMBER: 13135A00
 SHEET: 1 OF 1