

1025G

Wall Mounted Drinking Fountain



FEATURES & BENEFITS

Bubbler head

Patented (Pat.# 7,025,282) EnviroGard™ polished chrome-plated brass bubbler head provides sanitary service in the worst of conditions. The stainless steel shroud covers the orifice surface until the water is activated, and covers it again after use.

Drain Clean-Out

Top-down access to the drain allows the fountain to be cleaned without taking the unit apart, which is ideal for outdoor settings that are high in drain-clogging sediment like leaves, garbage, and other debris.

Construction

Heavy-duty 11 gauge galvanized steel incorporates a recessed push button and welded bubbler guard to provide extra durability, and a vandal-resistant bottom plate for added peace of mind. Stainless steel basin with a high-polished finish compliments almost any setting, and it also resists stains and corrosion.

Integrated Trap

Spacious fountain design allows for the trap to be internally mounted which allows for easy access, and aids and reduces the installation process.

Quality Control

Fountain is pre-built and fully water and pressure tested to ensure no leaks and proper function for reduced installation time and added peace of mind.

Push Button

With its patented (Pat.# 6,981,692) push-button valve assembly which allows for front access stream adjustment as well as cartridge and strainer access, this fountain offers the ultimate in ease of maintenance.



SPECIFICATIONS

Model 1025G wall mounted barrier-free drinking fountain shall include a stainless steel basin contained in an 11 gauge galvanized steel wall bracket, push-button operated valve with front-accessible cartridge and flow adjustment, polished chrome-plated brass vandal-resistant EnviroGard bubbler head with protective bubbler guard, polished chrome-plated brass vandal-resistant waste strainer with top-down access, vandal-resistant bottom plate, and chrome-plated 1-1/2" IPS trap.

OPTIONS

- Filter: Model 6426, 12" x 2", in-line lead removal element that reduces lead from incoming water supply.
- Mounting: Model 6700 universal mounting plate for most wall mounted fountains.
- Support Carrier: Model 6800 universal in-wall mounting support for use with most fountains.
- Chiller: Model HCR8, chiller provides for instantaneous cooling to meet a continuous demand for chilled water.

APPLICATIONS

Perfect for either public or private outdoor settings, Model 1025G is a great fit in areas where durability is important. Suitable in areas where weather conditions exist, this series is precisely mounted to make it a nice addition. Specifically, this type of wall mounted drinking fountain may be placed in settings such as: parks, schools, and other outdoor environments where the temperature remains above freezing.

Model meets all current Federal Regulations for the disabled including those in the Americans with Disabilities Act. Haws manufactures drinking fountains, electric water coolers and electric drinking fountains to be lead-free by all known definitions including ANSI/NSF Standard 61, Section 9, California Proposition 65, and the Federal Safe Drinking Water Act.



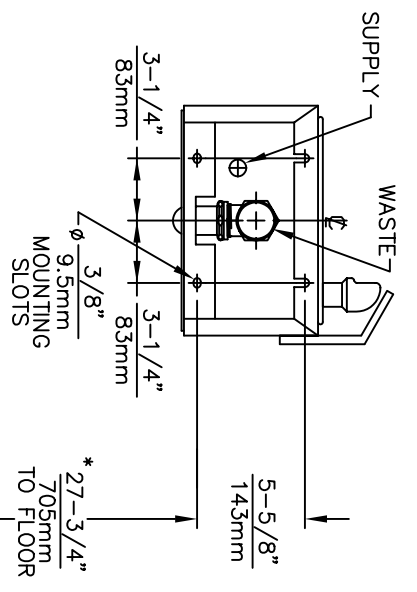

REAR VIEW MOUNTING DETAIL

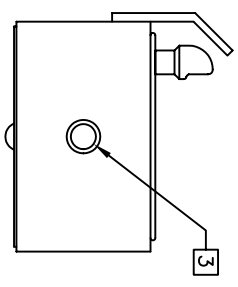
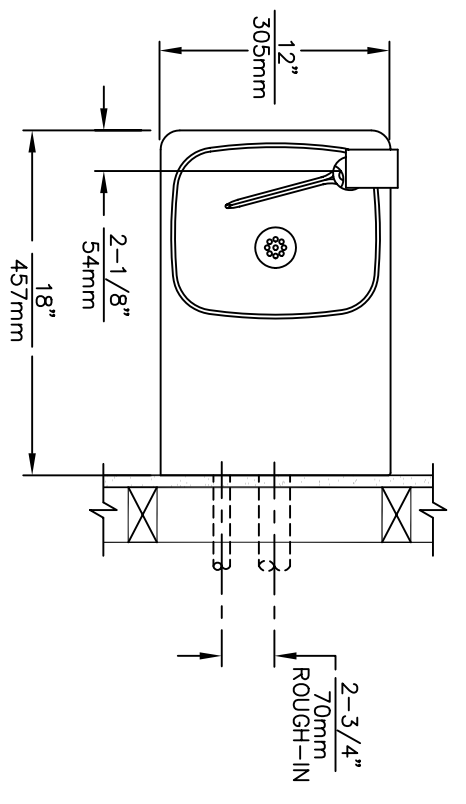

- NOTES:**
1. HOLD ROUGH-IN DIMENSIONS ±1/4" (6.4mm).
 2. WHEN INSTALLING THIS UNIT LOCAL, STATE OR FEDERAL CODES SHOULD BE ADHERED TO. FOR INSTALLATION HEIGHTS OTHER THAN SHOWN, ACCORDINGLY.
 3. REFER TO 5874/VRK5874 OPERATION AND MAINTENANCE MANUAL FOR PUSH BUTTON AND VALVE INSTALLATION/ MAINTENANCE INSTRUCTIONS.

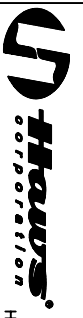
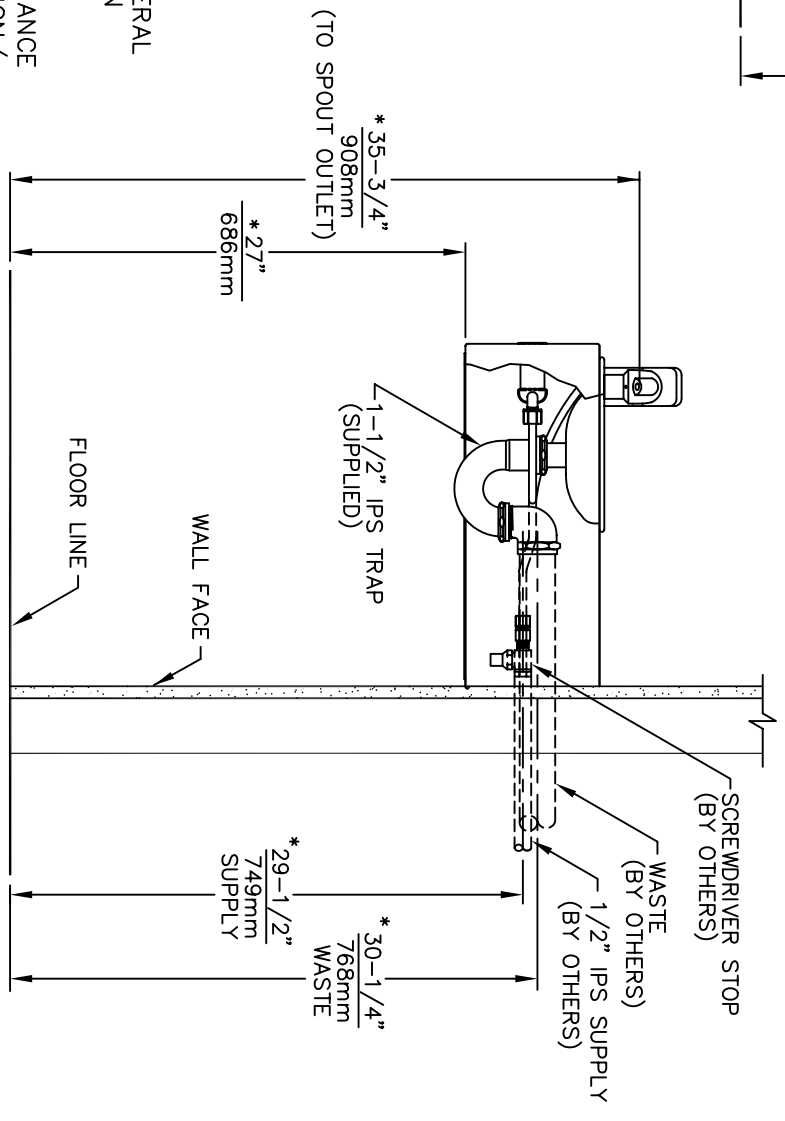

INFO FAX : 1-888-FAX-HAWS (1-888-329-4297)

1455 Kleppe Ln, Sparks NV, 89431
 Phone: 775-359-4712 Fax: 775-359-7424
 Haws Ag Bichweg 3 CH-3401 Burgdorf Switzerland
 Haws Mfg Pte Ltd 74 Sungai Kodul Loop Singapore 729531
 e-mail: Haws@hawsco.com Website: www.hawsco.com

DESIGNED BY	JF	CHECKED	
DRAWN			
CHECKED			
DATE	09/92		
TITLE	WALL MOUNTED DRINKING FOUNTAIN		
MODEL	1025/1025G		
INFO FAX DOC #	21025/210254		
SCALE	1:10	DRAWING TYPE	INSTALLATION/FABRICATION
PART NUMBER	0002076415.D	REV.	
DRAWING NUMBER	10371C00	REV.	10
SIZE	A	SHT	1 OF 1



INSTALLATION, OPERATION & MAINTENANCE INSTRUCTIONS

1455 Kleppe Lane ♦ Sparks, NV 89431-6467 ♦ (775) 359-4712 ♦ Fax (775) 359-7424
HAWS AG ♦ Bachweg 3 ♦ CH-3401 Burgdorf ♦ Switzerland
Haws Mfg. Pte Lt. ♦ 74 Sungei Kadut Loop ♦ Singapore 729531
E-mail: haws@hawsco.com ♦ website: www.hawsco.com

No. 2076415(10)

Model 1025/1025G Drinking Fountain

NOTE TO INSTALLER: Please leave this information with the Maintenance Department.

LIMITED WARRANTY

HAWS warrants that all of its products are guaranteed against defective material or poor workmanship for a period of **one year from date of shipment**. HAWS liability under this warranty shall be discharged by furnishing without charge F.O.B. HAWS Factory any goods, or part thereof, which shall appear to the Company upon inspection to be of defective material or not of first class workmanship, provided that claim is made in writing to company within a reasonable period after receipt of the product. Where claims for defects are made, the defective part or parts shall be delivered to the Company, prepaid, for inspection. HAWS will not be liable for the cost of repairs, alterations or replacements, or for any expense connected therewith made by the owner or his agents, except upon written authority from HAWS, Sparks, Nevada. HAWS will not be liable for any damages caused by defective materials or poor workmanship, except for replacements, as provided above. Buyer agrees that Haws has made no other warranties either expressed or implied in addition to those above stated, except that of title with respect to any of the products or equipment sold hereunder and that HAWS shall not be liable for general, special, or consequential damages claimed to arise under the contract of sale. The drinking fountain manufactured by HAWS is warranted to function if installation and maintenance instructions provided are adhered to. The units also must be used for the purpose for which they were intended.

NO OTHER WARRANTIES EXPRESSED OR IMPLIED ARE AUTHORIZED, PROVIDED OR GIVEN BY HAWS.

SHOULD YOU EXPERIENCE DIFFICULTY WITH THE INSTALLATION OF THIS MODEL, PLEASE CALL:

1-800-766-5612

(U.S.A. AND CANADA ONLY) MONDAY-THURSDAY: 6:00 A.M. – 4:00 P.M. PST
FRIDAY: 6:00 A.M – 1:00 P.M. PST

RECOMMENDED TOOLS: Hack saw, pipe joint sealant, screwdriver, level, 12" adjustable wrench, 10" pipe wrench, 5/64" hex key wrench, 9/16", 1/2", 7/16" socket wrench or open end wrench.

LOCATION OF UNIT: The Model 1025/1025G Drinking Fountain is a wheelchair accessible drinking water facility. The height dimensions shown meet current ADA requirements. When installing this unit, local, state or federal codes should be adhered to. If height other than shown is required, then dimensions must be adjusted accordingly.

SUPPLY LINE: The minimum recommended line size is 1/2"IPS with 30-90 psi (2-6 ATM) pressure. Where sediment or mineral content is a problem, an inlet filter is recommended.

PLUMBING CONNECTIONS: Inlet is 3/8"O.D. compression fitting. Waste outlet is female 1-1/2"IPS.

MAINTENANCE: Periodically clean the strainer. Refer to 5874 Valve Operation and Maintenance sheet for more information.

TROUBLESHOOTING

PROBLEM	REPAIR CHECKLIST
1. Insufficient bubbler flow.	1a. Check that inlet screwdriver stop valve (not supplied) is wide open. b. Verify minimum 30 psi supply pressure. c. Clean strainer. See 5874 Valve Manual d. Adjust valve to increase flow. Use front adjust screw or see 5874 Valve Manual.

ITEM	DESCRIPTION
1	TRAP SP95
2	STRAINER ASSY 6466
3	BUBBLER HEAD 5703M
4	PUSH BTN ASS'Y PBA7
5	VALVE 5874
6	ACCESS PLATE PBM1025

PARTS BREAKDOWN

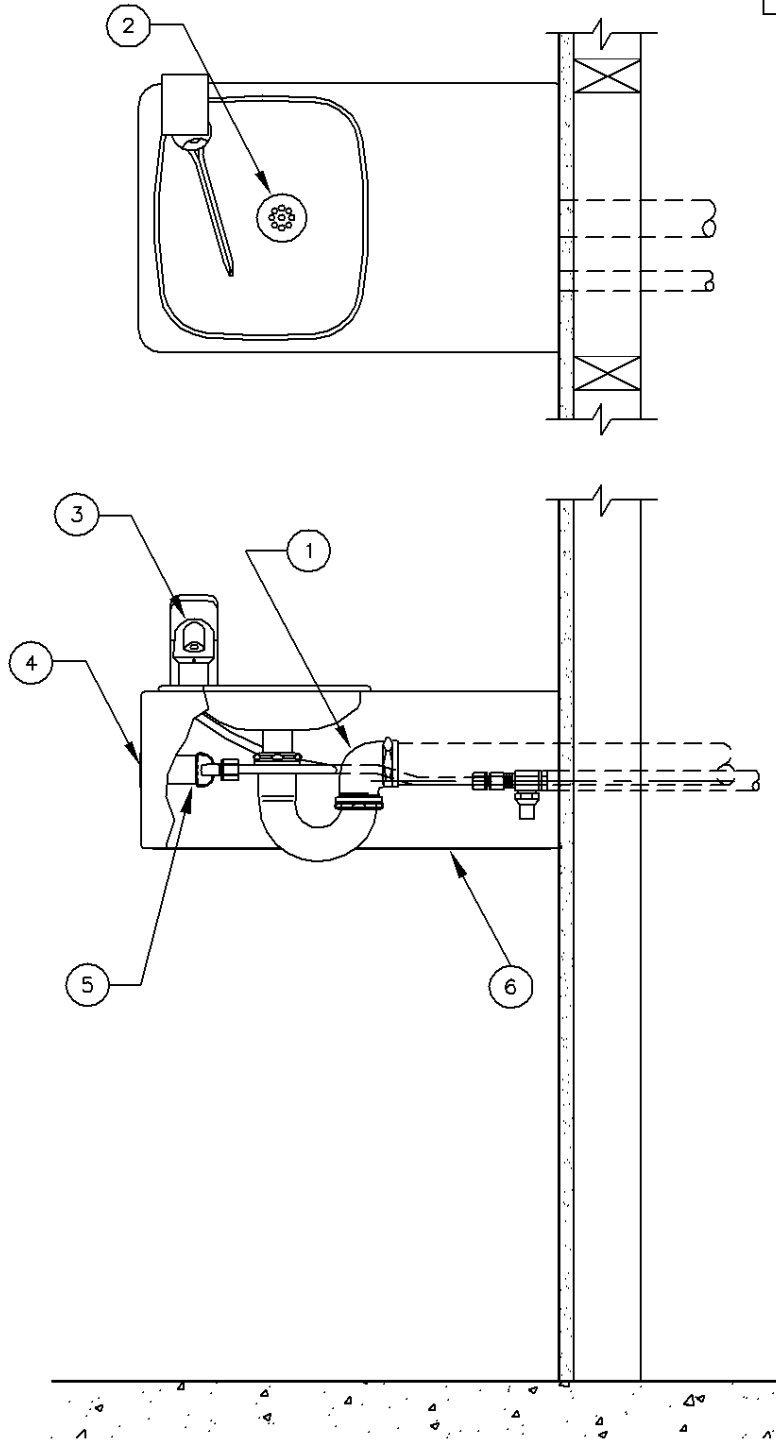

**WHEN ORDERING
PARTS PLEASE
SPECIFY YOUR
MODEL NUMBER**



1455 KLEPPE LANE BACHWEG 3
SPARKS, NEVADA CH3401 BURGDORF
SWITZERLAND

DRAWN BY: D OLLOM	DATE: 11/25/95	CHECK BY:	APPROV BY:	SCALE: 1/4
TITLE: 1025/1025G BREAKDOWN			PART NUMBER: 0002076415	
DRAWING TYPE: PARTS BREAKDOWN			DRAWING NUMBER: 12780C00	REV. 10

REV	DESCRIPTION	ECN	DATE	BY/APVD
REVISIONS				

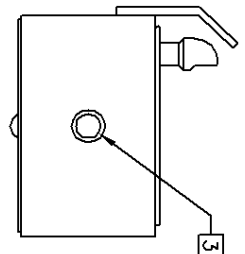
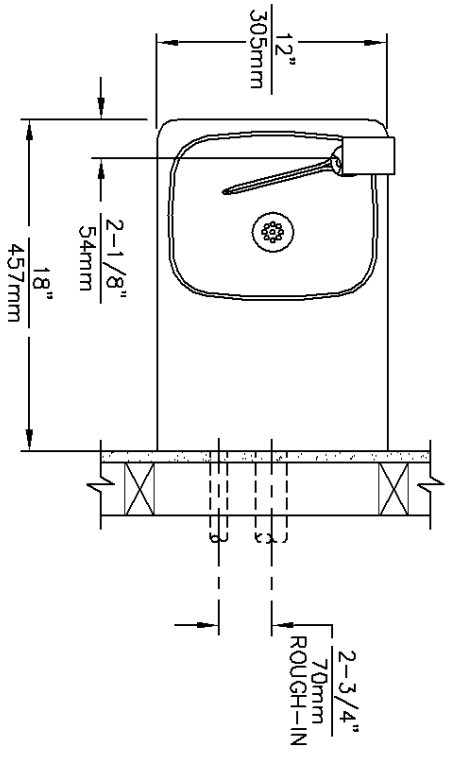
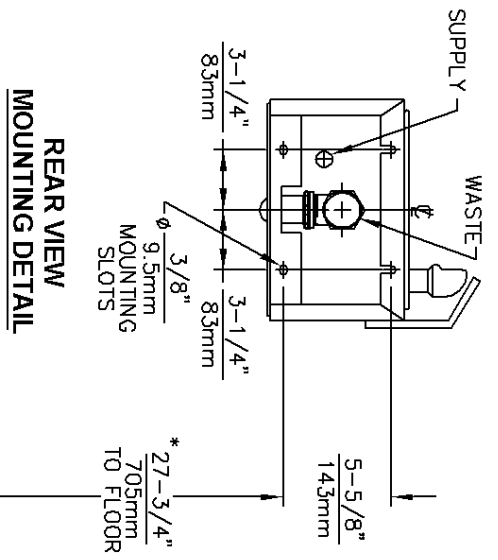

- NOTES:**
1. HOLD ROUGH-IN DIMENSIONS $\pm 1/4"$ (6.4mm).
 2. WHEN INSTALLING THIS UNIT LOCAL, STATE OR FEDERAL CODES SHOULD BE ADHERED TO. FOR INSTALLATION HEIGHTS OTHER THAN SHOWN, ACCORDINGLY.
 3. REFER TO 5874/YRK5874 OPERATION AND MAINTENANCE MANUAL FOR PUSH BUTTON AND VALVE INSTALLATION/ MAINTENANCE INSTRUCTIONS.

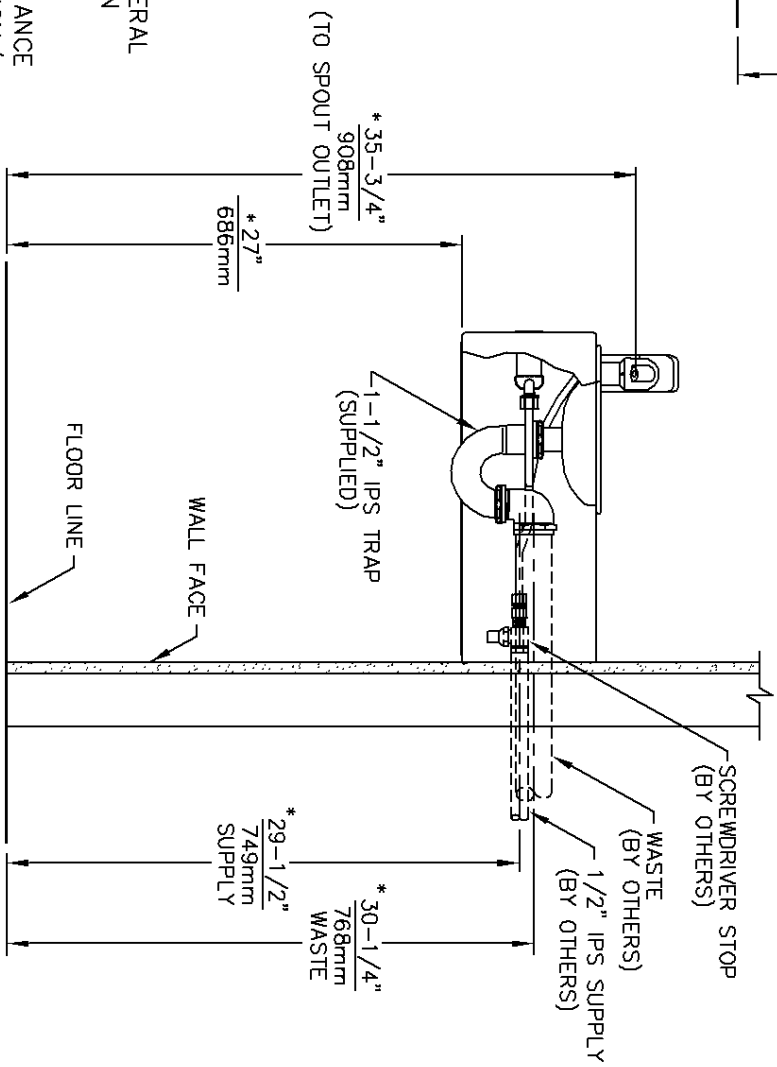

Haws Corporation

INFO FAX : 1-888-FAX-HAWS (1-888-329-4297)

1455 Kiege Ln, Sparks, NV 89431
 Phone: 775-359-4712 Fax: 775-359-7424
 Haws Ag, Bohlweg 3, CH-3401, Burgdorf, Switzerland
 Haws Mfg Pte Ltd, 74, Sungai Kedat, Loop, Singapore 729531
 e-mail: Haws@hawsco.com website: www.hawsco.com

TITLE: WALL MOUNTED DRINKING FOUNTAIN
 MODEL: 1025/1025G
 INFO FAX DOC #: 21025/210254
 SCALE: 1:10 DRAWING TYPE: INSTALLATION/BACK

DATE	BY	CHKD
09/92	C. LACEY	

REV 10
 10371C00