

# 1117L

## Wall Mounted Drinking Fountain



### FEATURES & BENEFITS

#### Back Panel

Stainless steel back panel helps to protect the wall from inadvertent splashing, and its decorative satin finish increases location visibility and completes the fountain's attractive appearance.

#### Integrated Trap

Spacious fountain design allows for the trap to be internally mounted which allows for easy access, and aids and reduces the installation process.

#### Antimicrobially Treated

Specific components are antimicrobially treated using the natural protection of silver. Silver helps protect against the growth of mold and mildew on the treated components. Treated surfaces include bubbler head, push button, waste strainer and trap.

#### Quality Control

Both fountains are pre-built and fully water and pressure tested to ensure no leaks and proper function for reduced installation time and added peace of mind.

#### Push Button

With its patented (Pat.# 6,981,692) push-button valve assembly which allows for front access stream adjustment as well as cartridge and strainer access, this fountain offers the ultimate in ease of maintenance.

#### Configurable

Supplied with a low profile bowl, individual adjustable panels, and multiple mounting positions, this fountain can be configured for adult and child ADA considerations.

#### Construction

Heavy-duty 14 gauge Type 304 Stainless Steel construction with integral 1/4" mounting plates for extra durability. Unit also includes vandal-resistant bottom plates for added peace-of-mind.

#### Bubbler Head

Polished chrome-plated brass bubbler head features an integral basin shank for added strength, and is equipped with a shielded, anti-squirt orifice that provides a steady sanitary source of water.



### SPECIFICATIONS

Model 1117L low profile "Hi-Lo" wall mounted barrier-free drinking fountain shall include dual 14 gauge Type 304 Stainless Steel satin finish basins with integral 1/4" stainless steel mounting plates, antimicrobially treated push-button, bubbler head, waste strainer, and trap to protect against the growth of mold and mildew on the treated components. Push-button operated valves with front-accessible cartridge and flow adjustment, polished chrome-plated brass vandal-resistant bubbler heads, polished chrome-plated brass vandal-resistant waste strainers, vandal-resistant bottom plates, stainless steel satin finish back panel, adjustable mounting allowing either basin high or low, in-wall mounting plate, and 1-1/4" IPS integral traps. Unit can be mounted to meet ADA or Child ADA specifications.

### APPLICATIONS

Perfect for either public or private indoor/outdoor settings, Model 1117L is a great fit in areas where aesthetics are important to the overall appeal of the architecture. This series is precisely mounted, making it a nice addition to any surrounding. Beautiful satin finish helps to maintain the fountain's overall appeal so it always remains looking as new as it did when it was installed. Specifically, this type of wall mounted drinking fountain may be placed in settings such as: schools and other locations in and around office buildings where the temperature remains above freezing.

Model meets all current Federal Regulations for the disabled including those in the Americans with Disabilities Act. Haws manufactures drinking fountains, electric water coolers and electric drinking fountains to be lead-free by all known definitions including ANSI/NSF Standard 61, Section 9, California Proposition 65, and the Federal Safe Drinking Water Act.

### OPTIONS

- Bubbler Head: Model 5725 EnviroGard™ bubbler is a polished chrome-plated solid brass bubbler head with stainless steel water activated pop up canopy. (Pat.# 7,025,282)
- Filter: Model 6426, 12" x 2", in-line lead removal element that reduces lead from incoming water supply.
- Support Carrier: Model 6800 universal in-wall mounting support for use with most fountains.
- Chiller: Model HCR8, chiller provides for instantaneous cooling to meet a continuous demand for chilled water.





**THIS DOCUMENT IS TRUE AND CORRECT AT TIME OF PUBLICATION. CONTINUED PRODUCT IMPROVEMENTS MAKE SPECIFICATIONS AND MEASUREMENTS SUBJECT TO CHANGE WITHOUT NOTICE.**

**NOTES:**

- HOLD ROUGH-IN DIMENSIONS  $\pm 1/8"$  (3.2mm).
- WHEN INSTALLING THIS UNIT, LOCAL, STATE OR FEDERAL CODES SHOULD BE ADHERED TO. FOR INSTALLATION DIMENSIONS (LOCATIONS), WASTE AND SUPPLY REQUIREMENTS OTHER THAN SHOWN, DIMENSIONS MARKED (\*) MUST BE ADJUSTED ACCORDINGLY.
- REFER TO 5874/VRK5874 OPERATION AND MAINTENANCE MANUAL FOR PUSH BUTTON AND VALVE INSTALLATION/MAINTENANCE INSTRUCTIONS.
- ROUGH IN DIMENSIONS FOR FOUNTAIN HEIGHTS:
  - CHILD WHEELCHAIR HEIGHT: SEE SHT 2 FIG 1
    - WASTE: 26-1/4" (667mm)
    - SUPPLY: 26-1/8" (664mm)
    - MOUNTING HOLE: 24-13/16" (630mm)
    - FOUNTAIN: 24" (610mm)
    - BUBBLER: 29-7/8" (756mm)
  - ADULT WHEELCHAIR HEIGHT: SEE SHT 2 FIG 2
    - WASTE: 29-1/4" (743mm)
    - SUPPLY: 29-1/8" (740mm)
    - MOUNTING HOLE: 27-13/16" (706mm)
    - FOUNTAIN: 27" (686mm)
    - BUBBLER: 32-7/8" (832mm)
- STANDING ADULT HEIGHT: SEE SHT 2 FIG 3
  - WASTE: 34-3/4" (883mm)
  - SUPPLY: 34-5/8" (879mm)
  - MOUNTING HOLE: 33-5/16" (846mm)
  - FOUNTAIN: 32-1/5" (826mm)
  - BUBBLER: 38-3/8" (972mm)

5. REFER TO MODEL 1117L INSTALLATION DRAWING SHEET 2 OF 2 (ON HAWS WEBSITE [WWW.HAWSCO.COM](http://WWW.HAWSCO.COM)) FOR PERMISSIBLE BOWL MOUNTING PATTERNS.  
**TWO WHEELCHAIR HEIGHT FOUNTAINS CANNOT BE MOUNTED SIDE BY SIDE PER ANSI A117.1**

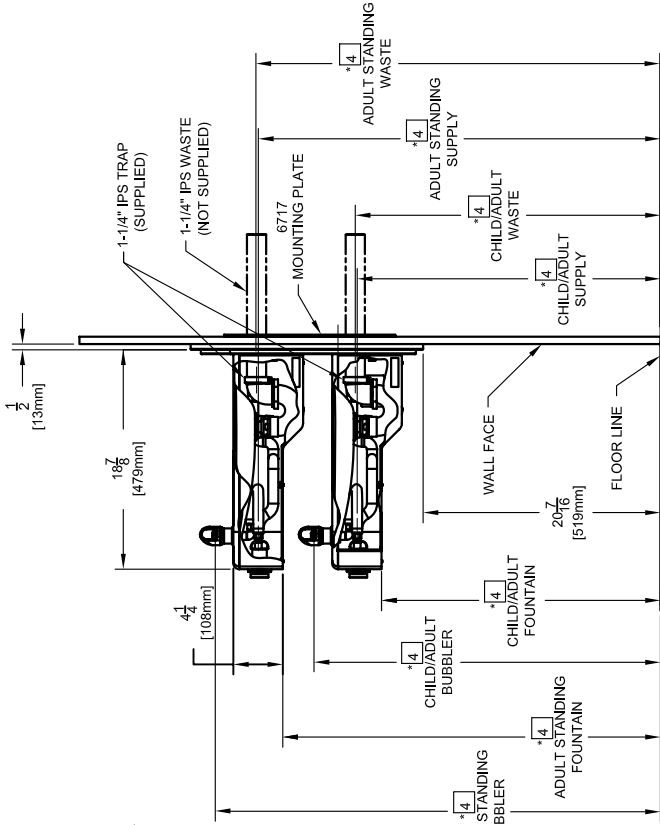
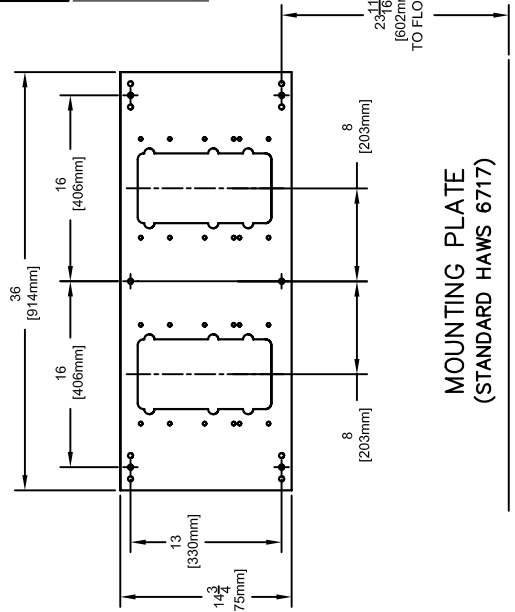
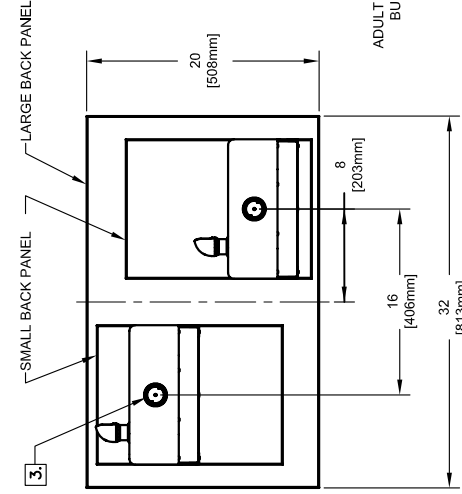
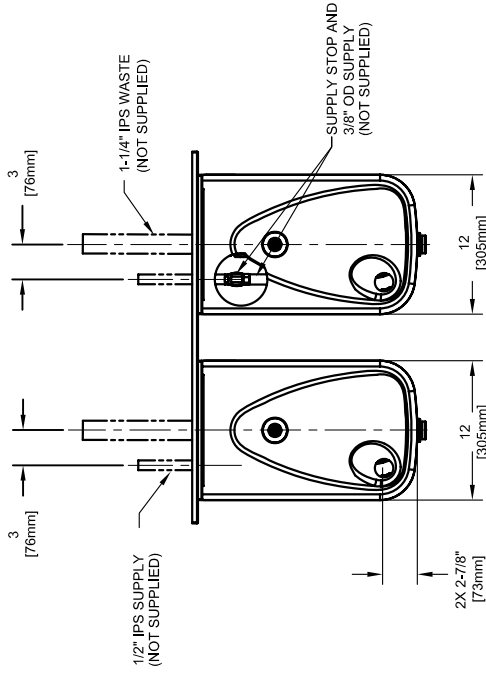
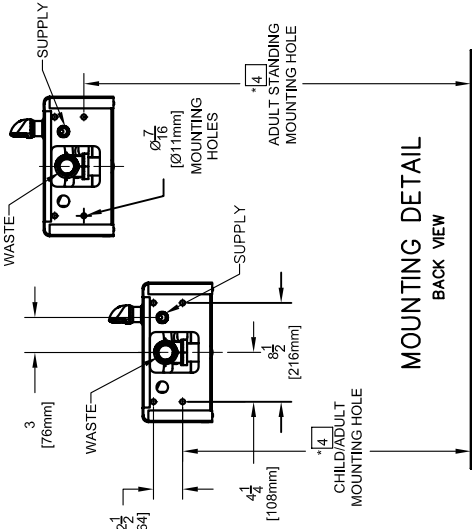
NOTES CONTINUED ON SHEET 2 OF 2

**INFO FAX : 1-888-FAX-HAWS (1-888-329-4297)**  
 1455 Kleppe Ln, Sparks NV, 89431  
 Phone: 775-359-4712 Fax: 775-359-7424  
 Haws Ag, Bachweg 3, CH-3401 Burgdorf Switzerland  
 Haws Mtg Pte Ltd 74 Sungai Kadut Loop Singapore 729531  
 e-mail: [Haws@hawsco.com](mailto:Haws@hawsco.com) website: [www.hawsco.com](http://www.hawsco.com)

REV	DATE	BY	CHKD	DATE	SCALE	TYPE
3782	10/06	1117L			1:1	INSTALLATION FEEDBACK

MODEL(S): 0007080223.D  
 DRAWING NUMBER: 15269A00  
 SHEET: 1 OF 2





# INSTALLATION, OPERATION & MAINTENANCE INSTRUCTIONS

1455 Kleppe Lane ♦ Sparks, NV 89431-6467 ♦ (775) 359-4712 ♦ Fax (775) 359-7424  
HAWS AG ♦ Bachweg 3 ♦ CH-3401 Burgdorf ♦ Switzerland  
Haws Mfg. Pte Lt. ♦ 2A Sungei Kadet Drive ♦ Singapore 729554  
Avlis-Avenida Senador, Testonio Vilela ♦ 505 Jardim Aeroporto ♦ Itu, S.P. 13304-550 ♦ Brasil  
E-mail: [haws@hawsco.com](mailto:haws@hawsco.com) ♦ website: [www.hawsco.com](http://www.hawsco.com)

No. 2080223 (5)

## Model 1117L Drinking Fountain

**NOTE TO INSTALLER:** Please leave this information with the Maintenance Department.

### LIMITED WARRANTY

HAWS® warrants that all of its products are guaranteed against defective material or poor workmanship for a period of **one year from date of shipment**. HAWS liability under this warranty shall be discharged by furnishing without charge F.O.B. HAWS Factory any goods, or part thereof, which shall appear to the Company upon inspection to be of defective material or not of first class workmanship, provided that claim is made in writing to company within a reasonable period after receipt of the product. Where claims for defects are made, the defective part or parts shall be delivered to the Company, prepaid, for inspection. HAWS will not be liable for the cost of repairs, alterations or replacements, or for any expense connected therewith made by the owner or his agents, except upon written authority from HAWS, Sparks, Nevada. HAWS will not be liable for any damages caused by defective materials or poor workmanship, except for replacements, as provided above. Buyer agrees that Haws has made no other warranties either expressed or implied in addition to those above stated, except that of title with respect to any of the products or equipment sold hereunder and that HAWS shall not be liable for general, special, or consequential damages claimed to arise under the contract of sale. The drinking fountain manufactured by HAWS is warranted to function if installation and maintenance instructions provided are adhered to. The units also must be used for the purpose for which they were intended.

**NO OTHER WARRANTIES EXPRESSED OR IMPLIED ARE AUTHORIZED, PROVIDED OR GIVEN BY HAWS.**

**SHOULD YOU EXPERIENCE DIFFICULTY WITH THE INSTALLATION OF THIS MODEL, PLEASE CALL:**

**1-800-766-5612**

**FOR PARTS CALL:**

**1-800-758-9378**

**(U.S.A. AND CANADA ONLY) MONDAY-THURSDAY: 6:00 A.M. – 4:00 P.M. PST  
FRIDAY: 6:00 A.M – 1:00 P.M. PST**

**RECOMMENDED TOOLS:** Hack saw, pipe joint sealant, screwdriver, level, 12" adjustable wrench, 10" pipe wrench, 5/64" hex key wrench, 9/16", 1/2", 7/16" socket wrench or open end wrench.

**LOCATION OF UNIT:** The Model 1117L Drinking Fountain is a wheelchair accessible drinking water facility. The height dimensions that are shown meet current ADA requirements. When installing this unit, local, state or federal codes should be adhered to. If height other than shown is required, then dimensions must be adjusted accordingly.

**SUPPLY LINE:** The minimum recommended line size is 1/2"IPS with 30-90 psi (2-6 ATM) flowing pressure. Where sediment or mineral content is a problem, an inlet filter is recommended.

**PLUMBING CONNECTIONS:** Inlet is 3/8"O.D. compression fitting. Waste outlet is female 1-1/4" IPS.

**MAINTENANCE:** Periodically clean the strainer. Refer to 5874 Valve Manual for more information.

### TROUBLESHOOTING

PROBLEM	REPAIR CHECKLIST
1. Insufficient bubbler flow.	1a. Check that inlet screwdriver stop valve is wide open. Turn counter-clockwise. b. Verify minimum 30 psi flowing supply pressure. c. Clean strainer. See 5874 Valve Manual d. Adjust valve to increase flow. Use front adjust screw or see 5874 Valve Manual.

# PARTS BREAKDOWN

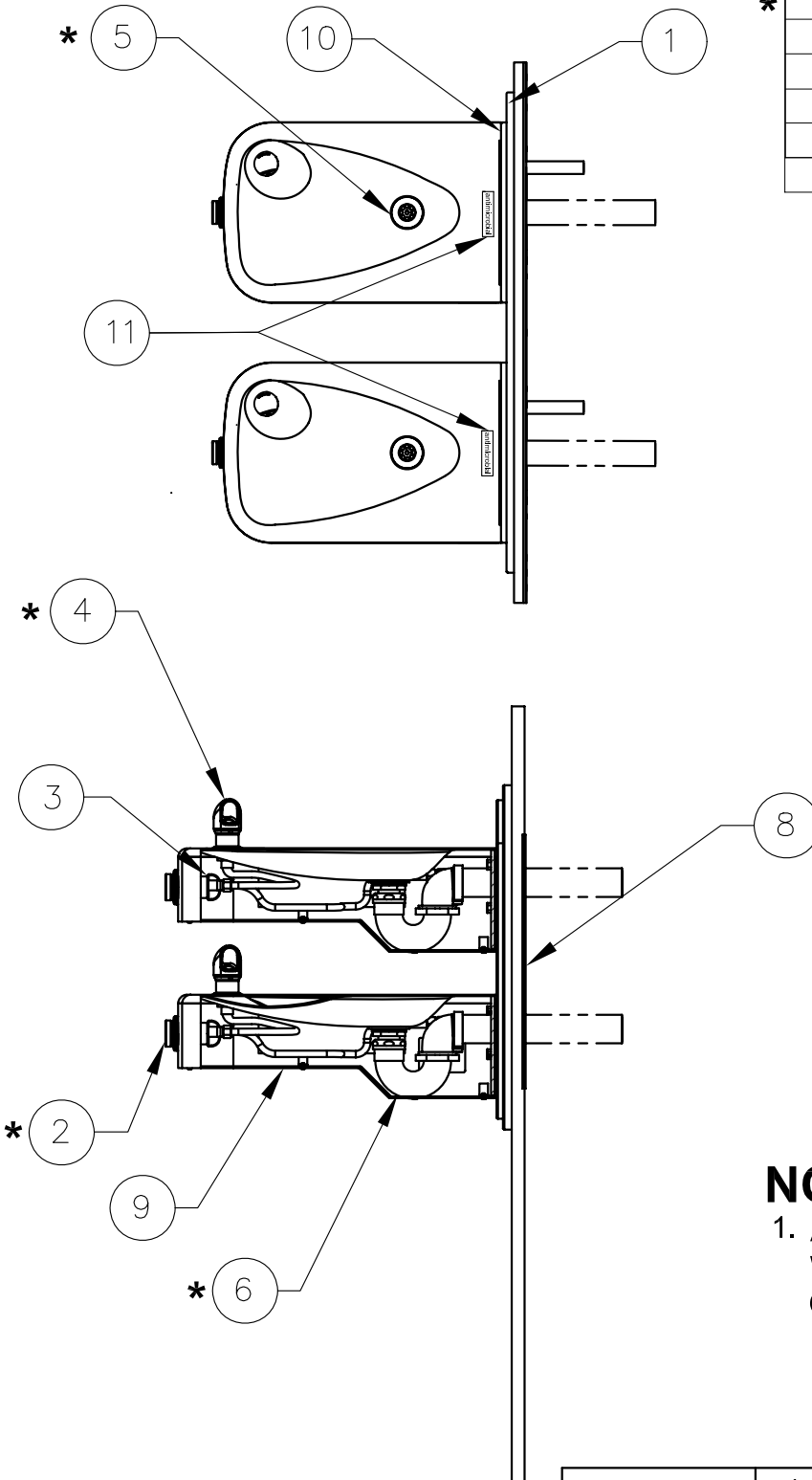

ITEM	DESCRIPTION
1	BACK PANEL P/N 0004023590
* 2	BUTTON ANTIMICROBIAL PBA6A
3	VALVE 5874
* 4	HEAD ANTIMICROBIAL 5703MA
* 5	STRAINER ANTIMICROBIAL 6462A
* 6	TRAP ANTIMICROBIAL 0005982901
7	SPANNER WRENCH P/N 0006983506
8	MOUNTING PLATE 6717
9	BOTTOM PLATE P/N 0004449315
10	SMALL BACK PANEL P/N 0004023587
11	LABEL ANTIMICROBIAL 0003149795

## NOTE:

1. ASTERISK (\*) DENOTES PARTS WITH AN ANTIMICROBIAL COATING.

**WHEN ORDERING PARTS PLEASE SPECIFY YOUR MODEL NUMBER**



1455 KLEPPE LANE | BACHWEG 3  
SPARKS, NEVADA | CH3401 BURGDORF  
SWITZERLAND

DRAWN BY: C.FENNER	DATE: 10/26/06	CHECK BY:	APP'D BY:	SCALE: 1/1
TITLE: 1117L			PART NUMBER: 0002080223	
DRAWING TYPE: PARTS BREAKDOWN			DRAWING NUMBER: 15268A00	REV: 5

THIS DOCUMENT IS TRUE AND CORRECT AT TIME OF PUBLICATION. CONTINUED PRODUCT IMPROVEMENTS MAKE SPECIFICATIONS AND MEASUREMENTS SUBJECT TO CHANGE WITHOUT NOTICE.

NOTES:

- HOLD ROUGH-IN DIMENSIONS  $\pm 1/8"$  (3.2mm).
- WHEN INSTALLING THIS UNIT, LOCAL, STATE OR FEDERAL CODES SHOULD BE ADHERED TO. FOR INSTALLATION DIMENSIONS (LOCATIONS), WASTE AND SUPPLY REQUIREMENTS OTHER THAN SHOWN, DIMENSIONS MARKED (\*) MUST BE ADJUSTED ACCORDINGLY.
- REFER TO 5874/VRK5874 OPERATION AND MAINTENANCE MANUAL FOR PUSH BUTTON AND VALVE INSTALLATION/MAINTENANCE INSTRUCTIONS.
- ROUGH IN DIMENSIONS FOR FOUNTAIN HEIGHTS:
  - CHILD WHEELCHAIR HEIGHT: SEE SHT 2 FIG 1
    - WASTE: 26-1/4" (667mm)
    - SUPPLY: 26-1/8" (664mm)
    - MOUNTING HOLE: 24-13/16" (630mm)
    - FOUNTAIN: 24" (610mm)
    - BUBBLER: 29-7/8" (756mm)
  - ADULT WHEELCHAIR HEIGHT: SEE SHT 2 FIG 2
    - WASTE: 29-1/4" (743mm)
    - SUPPLY: 29-1/8" (740mm)
    - MOUNTING HOLE: 27-13/16" (706mm)
    - FOUNTAIN: 27" (686mm)
    - BUBBLER: 32-7/8" (832mm)
- STANDING ADULT HEIGHT: SEE SHT 2 FIG 3
  - WASTE: 34-3/4" (883mm)
  - SUPPLY: 34-5/8" (879mm)
  - MOUNTING HOLE: 33-5/16" (846mm)
  - FOUNTAIN: 32-1/5" (826mm)
  - BUBBLER: 38-3/8" (972mm)

5. REFER TO MODEL 1117L INSTALLATION DRAWING SHEET 2 OF 2 (ON HAWS WEBSITE [WWW.HAWSCO.COM](http://WWW.HAWSCO.COM)) FOR PERMISSIBLE BOWL MOUNTING PATTERNS.  
**TWO WHEELCHAIR HEIGHT FOUNTAINS CANNOT BE MOUNTED SIDE BY SIDE PER ANSI A117.1**

NOTES CONTINUED ON SHEET 2 OF 2

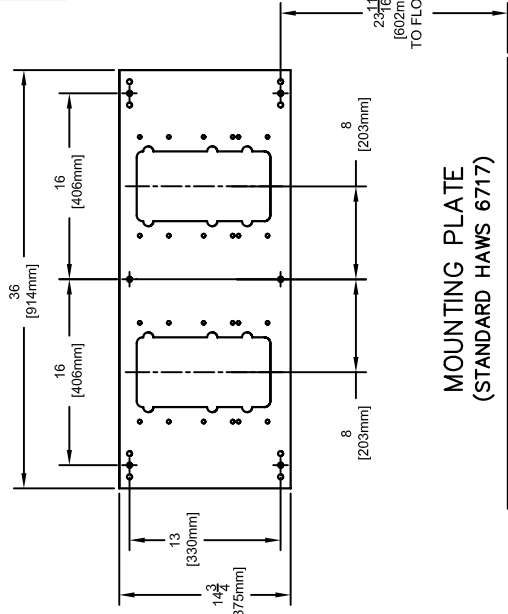
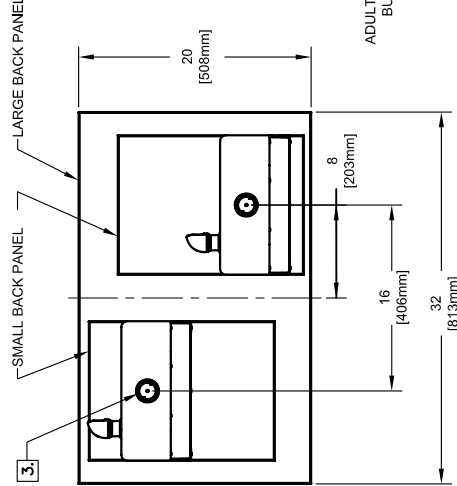
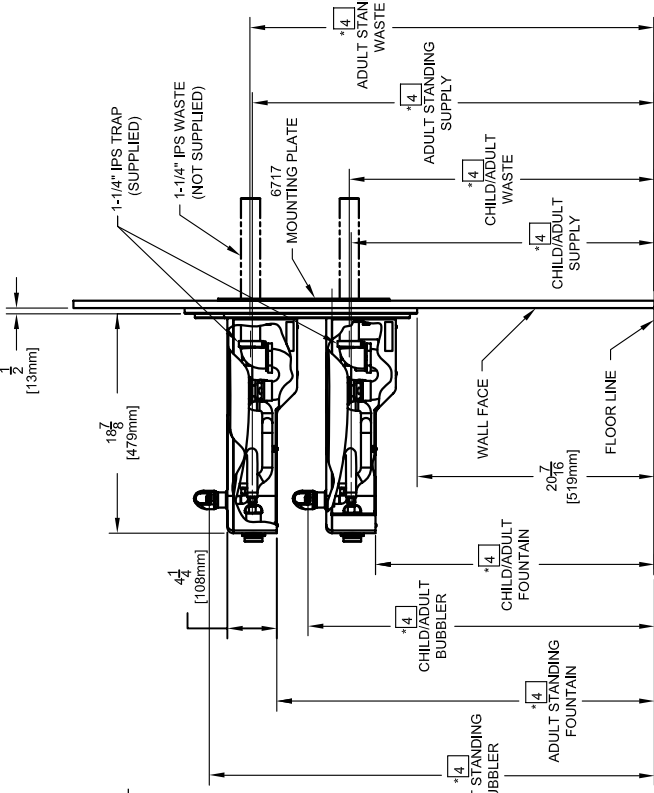
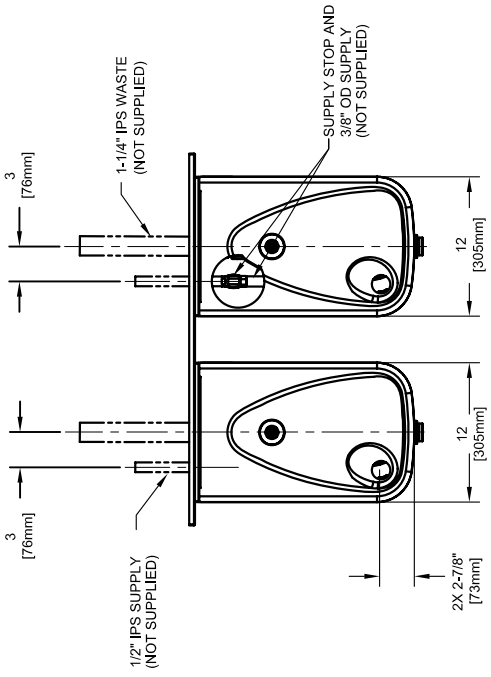
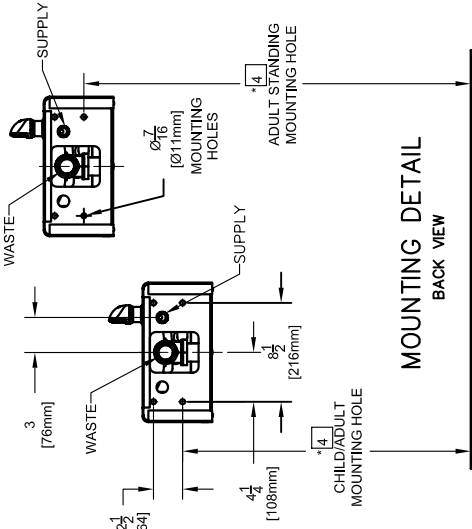

MOUNTING PLATE (STANDARD HAWS 6717)

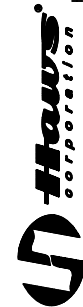

INFO FAX : 1-888-FAX-HAWS (1-888-329-4297)  
 1455 Kleppe Ln, Sparks NV, 89431  
 Phone: 775-359-4712 Fax: 775-359-7424  
 Haws Ag, Bachweg 3, CH-3401 Burgdorf Switzerland  
 Haws Mtg Pte Ltd 74 Sungai Kadut Loop Singapore 729531  
 e-mail: [Haws@hawco.com](mailto:Haws@hawco.com) website: [www.hawco.com](http://www.hawco.com)

REV	DATE	BY	CHKD	DATE	SCALE	HT	INSTALLATION FEEDBACK
3782	10/06	1117L	1117L				
MODEL(S):							1117L
INFO FAX DOC #:							211175
TRAINING TYPE:							INSTALLATION FEEDBACK
DRAWING NUMBER:							15269A00
SHEET:							A
OF:							2

NOTES:

- 6. FIGURES 1 AND 2 ARE REVERSIBLE. CAN BE RIGHT OR LEFT SIDE HIGH.
- 7. USE SHADED HOLES TO MOUNT AT INDICATED POSITIONS BASED ON COMBINATION SELECTED (FIGS. 1 THRU 3).
- 8. REFER TO SHEET 1 OF 2 NOTE 4 FOR INSTALLED FOUNTAIN DIMENSIONS.

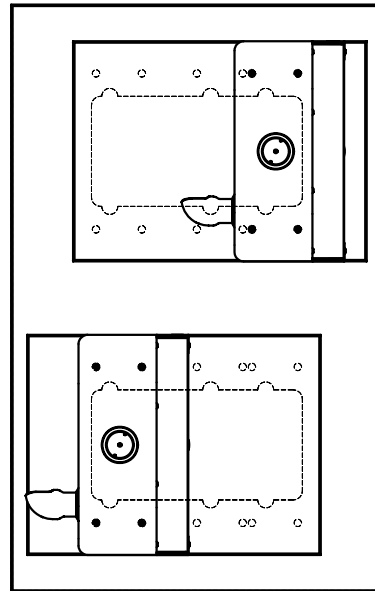

6. FIGURE 1. ADULT STANDING/CHILD WHEELCHAIR

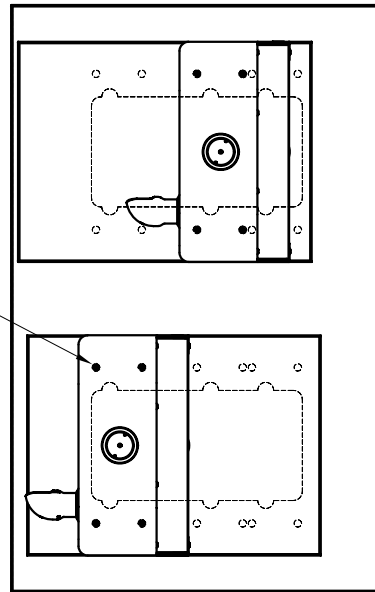

6. FIGURE 2. ADULT STANDING/ADULT WHEELCHAIR

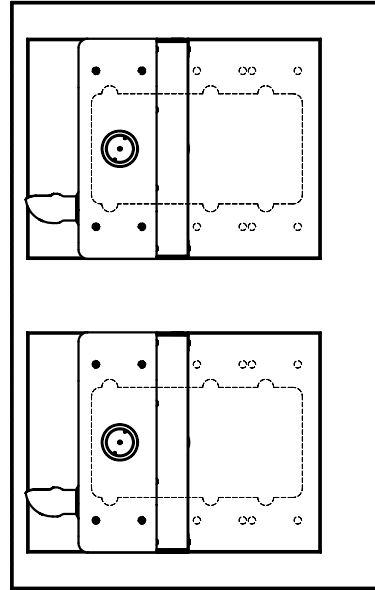
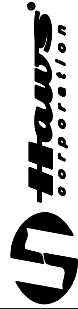

FIGURE 3. ADULT STANDING/ADULT STANDING

# BOWL MOUNTING PATTERNS



INFO FAX : 1-888-FAX-HAWS (1-888-329-4297)  
 1455 Kleppe Ln, Sparks NV, 89431  
 Phone: 775-359-4712 Fax: 775-359-7424  
 Haws Ag, Bachweg 3, CH-3401 Burgdorf Switzerland  
 Haws Mfg Pte Ltd 74 Sungai Kadut Loop Singapore 729531  
 e-mail: Haws@hawsco.com website: www.hawsco.com

REV. NO.	ISSUED FOR	DATE	BY
3782	ECN: 4148	11/17	G.FENNER
DATE	DATE	INFO FAX DOC #	SCALE
12-29-06	11/17	211175	1:1
APPROVER	DATE	TRAINING TYPE	INSTALLATION FEEDBACK

MODEL(S)	0007080223.D
DRAWING NUMBER	15269A00
SCALE	A SH. 2 OF 2