



WATER COOLERS

INSTALLATION/MAINTENANCE INSTRUCTIONS

A172.8UBL Series Refrigerated Universal Bi-Level Barrier Free, Wall Mounted Water Cooler



Alternate Configuration

OR



Standard Configuration



A172108F-UBL / A172408F-UBL / A172108F-SO / A172408F-SO

TECHNICAL ASSISTANCE TOLL FREE TELEPHONE NUMBER:

1.800.591.9360

Technical Assistance Fax: 1.626.855.4894

NOTES TO INSTALLER:

1. Please leave this documentation with the owner of the fixture when finished.
2. Please read this entire booklet before beginning the installation.
3. Check your installation for compliance with plumbing, electrical and other applicable codes.

LIMITED WARRANTY - UNITED STATES & CANADA

Murdock warrants that its products are free from defects in material or workmanship under normal use and service for a period of one year from date of install or for 18 months after the date of shipment from the factory, whichever comes first. The sealed refrigeration system is warranted for five years. Murdock's liability under this warranty shall be discharged solely by replacement or repair of defective material, provided Murdock is notified in writing within one year from date of shipment, F.O.B. Industry, California.

This warranty does not cover installation or labor charges and does not apply to materials, which have been damaged by other causes such as mishandling or improper care or abnormal use. The repair or replacement of the defective materials shall constitute the sole remedy of the Buyer and the sole remedy of Murdock under this warranty. Murdock shall not be liable under any circumstances for incidental, consequential or direct charges caused by defects in the materials, or any delay in the repair or replacement thereof. This warranty is in lieu of all other warranties expressed or implied. Product maintenance instructions are issued with each unit and disregard or non-compliance with these instructions will constitute an abnormal use condition and void the warranty. Stainless steel must be protected on job site during construction and must be properly maintained after the water has been introduced into the water cooler or drinking fountain, or Murdock's limited warranty is void.

LIMITED EXPORT WARRANTY - One year on parts only.

Murdock assumes no responsibility for use of void or suspended data. © Copyright Murdock, City of Industry, CA Member of Morris Group International. Please visit www.murdockmfg.com for most current specifications.

COMPLIES WITH
STANDARDS



NSF/ANSI 61



Federal Public Law 111-380 (No Lead)

Test rating conditions are compliant with ARI 1010.



Member of MORRIS GROUP INTERNATIONAL

MURDOCK
15125 Proctor Ave.
City of Industry, CA
91746 U.S.A.
Phone 800-591-9360
626-336-4561
Fax 626-855-4894

www.murdockmfg.com

7020-905-001

Date: 03/30/17



WATER COOLERS

INSTALLATION/MAINTENANCE INSTRUCTIONS

IMPORTANT

This fixture is intended to dispense water that has been lowered in temperature, but otherwise remains unchanged by the materials in the water cooler. It is common for electrical equipment to be grounded to water lines either within a structure or away from it. Every attempt should be made to prevent this kind of grounding from generating electrical feedback into the water cooler creating electrolysis. Electrolysis will cause a metallic taste or cause water metal content to increase.

NOTICE

A dielectric coupling must be used to connect the water cooler to the water supply. A nonmetallic coupler is furnished with this water cooler to meet this requirement.

ROUGHING-IN AND DIMENSIONAL DRAWING

Prior to roughing consult with local, state, and federal codes for proper mounting height.

A172.8UBL SERIES REFRIGERATED BI-LEVEL WALL MOUNTED WATER COOLER

Note: there are no mounting changes to be made for -SO models.

- A. 3/8" NCT SUPPLY INLET
- B. WASTE OUTLET FOR 1-1/4" P-TRAP BY OTHERS.
- C. ELECTRICAL SERVICE ROUGH.
- D. Ø3/8" HANGER BRACKET PUNCHING, 3 PLACES FOR ANCHORING HARDWARE BY OTHERS.
- E. Ø1/4" PUNCHING, 2 PLACES FOR ANCHORING HARDWARE BY OTHERS.

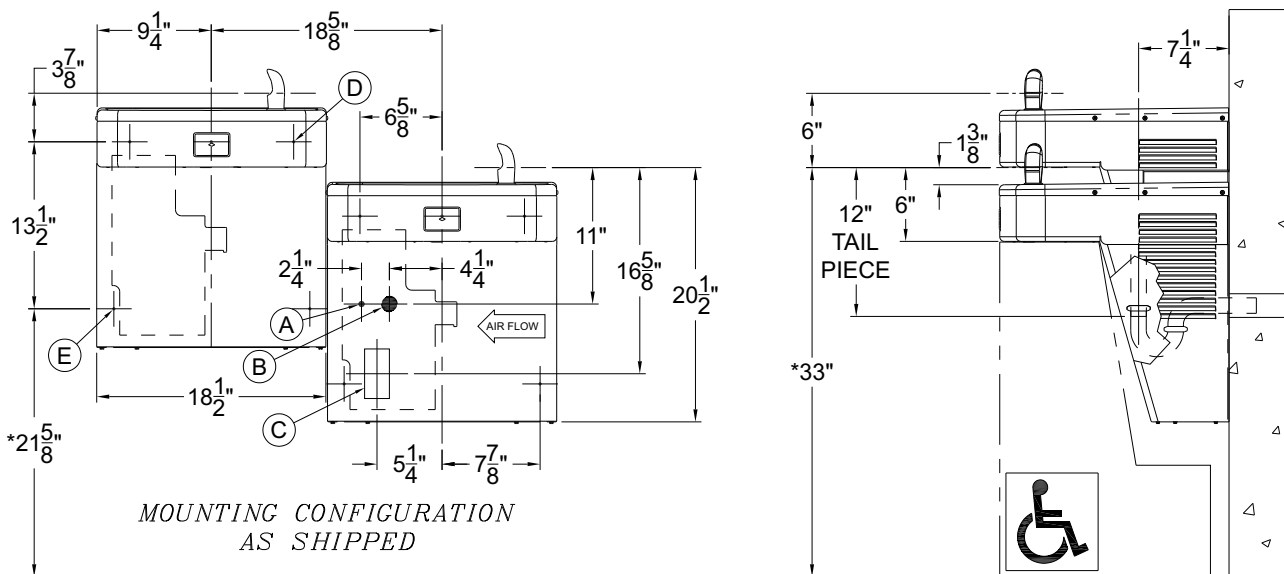

NOTES:

1. Dimensions shown for ADA compliant installation. For Child ADA 2010 compliant parallel approach installation, decrease height of * dimensions by 2-3/4".
2. Provide clear floor space as required. Adjust vertical dimensions as required to comply with federal, state, and local codes.

See next page for alternative mounting of units, roughing-in and dimensional drawing.



WATER COOLERS

INSTALLATION/MAINTENANCE INSTRUCTIONS

A172.8UBL SERIES REFRIGERATED BI-LEVEL WALL MOUNTED WATER COOLER

Note: there are no mounting changes to be made for -SO models.

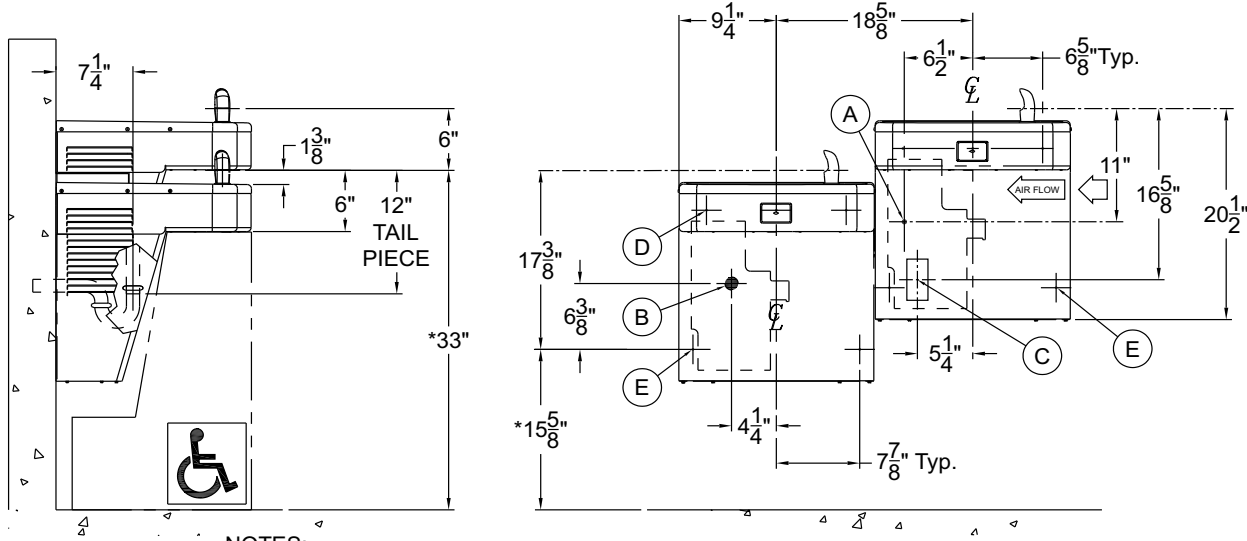

NOTES:

- A. 3/8" NCT SUPPLY INLET
- B. WASTE OUTLET FOR 1-1/4" P-TRAP BY OTHERS.
- C. ELECTRICAL SERVICE ROUGH.
- D. Ø3/8" HANGER BRACKET PUNCHING, 3 PLACES FOR ANCHORING HARDWARE BY OTHERS.
- E. Ø5/16" PUNCHING, 2 PLACES FOR ANCHORING HARDWARE BY OTHERS.

IMPORTANT:

1. Waste P-Trap, Water Supply Service Angle Stop Valve and 2" x 4" Electrical Plug-In Receptacle to be supplied by others in accordance with local codes. A metallic p-trap (by others) must be used for the drain connection.
2. Provide 4" minimum clear space on fixture sides to allow for proper ventilation through cabinet louvers.
3. Water supply is 3/8" Outside Diameter copper tube. Waste is 1-1/4" Outside Diameter.
4. Completely flush supply lines of all foreign debris before connecting to fixture. Water cooler designed to not affect taste, odor, color, or sediment. Optional water filter (Wf1) is available should any of these problems arise from the water supply.
5. Do **NOT** solder copper tube when inserted into the coupler as damage to the o-ring will result.
6. All burrs must be removed from outside of cut tubes before inserting into coupler or other components.
7. Power supply must be identical in voltage, cycle and phase to that specified on the cooler data plate. Electrical outlet and furnished power cord with plug must be used to supply power to fixture. Do **NOT** wire compressor directly to the power supply.
8. This unit must be grounded per the requirements of applicable electrical codes.
9. **Warranty is voided** if installation is not made following current Acorn Engineering installation instructions and if components are assembled to the fixture that is not approved by Acorn Engineering.
10. Fixture operates within water pressure range of 20 to 105 psig. Acorn Engineering will not warranty fixtures damaged when connected to supply lines with flow pressure lower than 20 psig or higher than 105 psig. A pressure regulator must be furnished by others on supply line if inlet pressure is greater than 105 psig.
11. Due to cold waste water, Acorn Engineering recommends that p-trap supplied by installer be insulated to prevent excessive condensation.
12. Per UPC 609.10- *All building water supply systems in which quick acting valves are installed shall be provided with devices to absorb the hammer caused by high pressure resulting from the quick closing of the valve. These pressure-absorbing devices shall be approved mechanical devices. Water pressure-absorbing devices will be installed as close as possible to the quick closing valve.*



WATER COOLERS INSTALLATION/MAINTENANCE INSTRUCTIONS

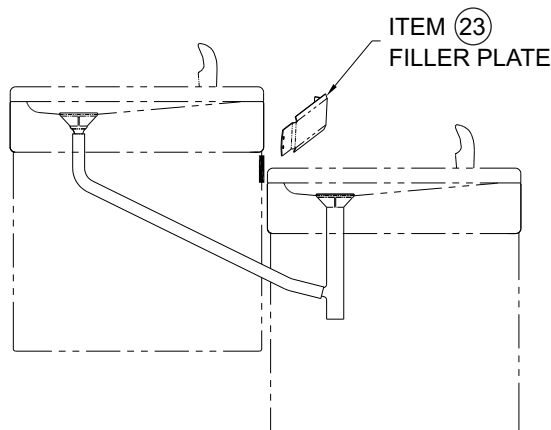

STANDARD WASTE CONFIGURATION

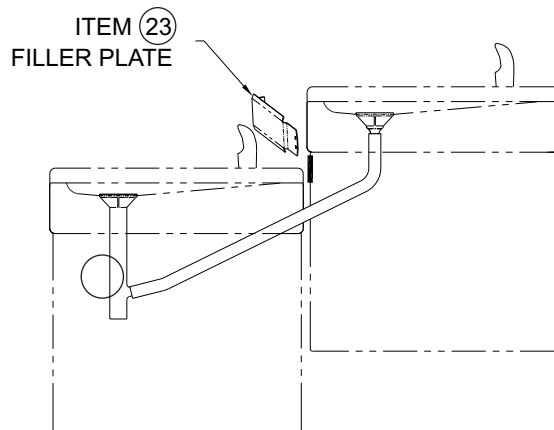

ALTERNATE WASTE CONFIGURATION

INSTALLATION:

Choose configuration; Remove and reinstall filler plate, item (23) and reverse drain assembly if required for alternate mounting configuration.

1. Mount hanger bracket to wall horizontally level as shown in Roughing-In and Dimensional Drawing. Note: Adjust height of bracket if bubbler outlet height is required to vary from that shown. Hanger Bracket **MUST** be securely anchored to wall with fasteners sufficient to support 3 times the weight of cooler. If wall can not provide adequate support, order and install optional fixture support carrier.
2. Remove the bottom cover from the water cooler and set aside in a safe place. Save the screws in a secure location for re-use in later stages of installation.
3. Hang the water coolers on the hanger brackets ensuring the bracket tabs engage **AND** seat in the slots in the back of the water coolers. **NOTE:** Hanging of refrigerated unit first is recommended since it is the heavier of the two. Verify water coolers are level, left to right **AND** front to back from bottom of unit. **CAUTION:** The bubbler stream may be adversely affected if units are not square and level. Bottom of units and louvers should be used as reference to verify unit is square and plumb.
4. Anchor the water coolers to the wall at the lower mounting points in each back panel. Shim lower mounting points to level unit if necessary.
5. Outlet tube from evaporator has an in-line tee with a tube going to the refrigerated unit's valve and the "TEE" not connected. Connect the loose supply tube from refrigerated unit to the "TEE".
6. Thoroughly flush the 3/8" O.D. supply line and then connect water cooler to water supply angle stop valve (by others) with supplied 3/8" O.D. copper tube.
7. Use supplied flexible hose and clamps to connect waste tailpiece from the upper unit to the waste tailpiece of lower unit and then make up 1-1/4" O.D. p-trap waste connection. Waste p-trap by others.



WATER COOLERS INSTALLATION/MAINTENANCE INSTRUCTIONS

START UP:

1. Before connecting power supply and assembling bottom cover to water cooler, but after thoroughly flushing the supply line and connecting it to the fixture, turn on building water supply and check all connections for leaks.
2. Air within the water cooler system or the structure supply piping will cause an irregular bubbler outlet stream until purged out by incoming water. Covering the bubbler with a clean cup (or similar object) is recommended when first activating water cooler to prevent excessive splashing. Depress the pushbutton until steady water stream is achieved.
3. If water flow requires adjustment, insert a slotted narrow blade screwdriver through the hole centered on the pushbutton to the flow regulator. Turning clockwise will increase flow and turning counterclockwise will decrease flow.
4. Recheck all water and drain connections with water flowing through system.
5. With power still **NOT** connected, carefully manually rotate cooling fan to insure proper clearance and free fan action.
6. Plug water cooler in to electrical outlet and make sure unit begins to function.
7. Assemble bottom cover to water cooler with screws furnished.

TROUBLE SHOOTING:

IMPORTANT: BEFORE MAKING ANY OF THE REPAIRS LISTED, MAKE SURE THE WATER COOLER IS DISCONNECTED FROM THE ELECTRICAL SUPPLY AND THE WATER SUPPLY VALVE IS SHUT OFF.

IMPORTANT : ASSUREZ-VOUS QUE LA FONTAINE D'EAU POTABLE RÉFRIGÉRÉE SOIT DÉBRANCHÉE DE LA PRISE DE COURANT MURALE ET QUE LE ROBINET D'ALIMENTATION D'EAU SOIT FERMÉ AVANT D'EFFECTUER LES RÉPARATIONS NÉCESSAIRES.

1. Adjustments
 - a. Cartridge – The water flow can be adjusted through the pushbutton using a straight blade screwdriver and turning clockwise to increase flow and counterclockwise to decrease flow.
 - b. Cold Water Thermostat – The water temperature can be adjusted using a slotted screwdriver and turning clockwise to make colder and counterclockwise to make warmer.
 - c. Bubbler Stream – Bubbler can be rotated slightly to direct the stream backwards or forwards. Adjust the stream to minimize splashing. Splashing may occur from bubbler stream if the unit is not level. Shim lower mounting points, if necessary, to level cooler.
2. Compressor Does Not Run
 - a. Check the electrical receptacle for power and correct voltage. The incoming voltage must be within 10% of the rated voltage on the serial nameplate.
 - b. The cold thermostat is accessible by removing the bottom access cover. If the cold thermostat capillary bulb loses its charge or becomes kinked it will fail in the open position causing a disruption of power to the compressor. Unplug the water cooler and using an ohm meter check for continuity across the two electrical terminals on the thermostat. Install a new thermostat if there is no continuity.
 - c. Check for loose wires within the compressor box. The incoming power leads must be connected to the overload and relay.
 - d. If all components check positive for continuity then test the wiring harness plug for continuity to see if there is a broken wire within the wiring harness insulation.
3. Compressor Runs – Water Is Warm
 - a. The most common cause for a water cooler to run without producing cold water is a loss of refrigerant. The water cooler must be taken to a certified refrigerant technician for repairs.
 - b. Make sure the condenser fan motor is operative. The fan blade must turn freely to help remove the heat of compression.



WATER COOLERS INSTALLATION/MAINTENANCE INSTRUCTIONS

- c. An incorrect refrigerant charge, restriction or defective compressor (not pumping) will also cause the compressor to run without producing cold water. All these signs indicate a problem within the refrigeration system and the water cooler must be checked by an authorized service company.
4. Compressor Cycling On Overload Protector
 - a. A dirty condenser or a blocked fan will cause a high head pressure and frequent cycling of the overload protector.
 - b. Check the incoming voltage to make sure it is within 10% of the serial nameplate rating.
 - c. A restriction or moisture in the system will also cause intermittent cycling. A certified refrigeration mechanic should be contacted in this situation.
 - d. Change the overload or relay if defective.
 5. Noisy Operation
 - a. Check to make sure the fan blade is rotating freely.
 - b. Make sure the water cooler is correctly mounted to the wall. Absence of the two lower mounting bolts may cause excess noise and vibration.
 - c. Check the compressor mounting to make sure the pins and clips are not rattling. If the compressor appears to be noisy internally, it must be replaced.
 6. Restricted Or No Water Flow
 - a. Ensure water supply service stop valve is fully open.
 - b. Verify minimum 20 psig supply line flow pressure.
 - c. Check for twists or kinks in bubbler tubing.
 - d. Check the water inlet strainer. Sediment from the main supply can get trapped in the screen along with installation materials such as pipe dope and flux. The screen should be cleaned and checked on a regular basis and replace if needed.
NOTE: STRAINER SCREEN MUST BE IN PLACE FOR WATER TO FLOW.
 - e. The cartridge valve located in the water control assembly or bubbler can also become clogged with foreign material. The cartridge valve can only be replaced and not repaired.
 - f. Check flow adjustment. See start up note #3.
 - g. The water cooler may also develop a freezing condition in which the water will become frozen inside the evaporator coil. This indicates a refrigeration problem or thermostat failure in which case the water cooler needs to be checked by a qualified technician.
 7. Water Drip Or Will Not Shut Off:
 - a. Remove Pushbutton Adjust flow regulator to the highest setting using a flat head screwdriver and turning clockwise. Check if water drip continues, if it is no longer dripping turn screwdriver counter-clockwise until you have desired flow rate. Assure that retaining nut is tighten to valve assembly, 25 in-lb torque is required. If issue still continues after adjusting flow and tightening retainer nut, replacement of the flow regulator cartridge will be required.

CLEANING & MAINTENANCE GUIDE:

1. Motors have lifetime lubrication and do not require scheduled maintenance.
2. Excess dirt or poor ventilation will cause the compress` more frequently.
3. Periodically remove access panels and clean out in-line strainer.
4. Do NOT use harsh chemicals, abrasive or petroleum based cleaners. Use of these will void the Acorn warranty.
5. Exterior panels can be cleaned using mild household detergents or warm, soapy water. Extra care must be used cleaning chrome plated items and mirror finished stainless steel. They can scratch easily and should only be cleaned using a clean, soft cloth and mild soap with water or a mild glass cleaner.



WATER COOLERS

INSTALLATION/MAINTENANCE INSTRUCTIONS

CARTRIDGE REPLACEMENT/ STRAINER MAINTENANCE

Note: Use the universal maintenance tool to perform the following:

1. Strainer plug must be removed before cartridge replacement and strainer maintenance (no need to turn the water off at the angle stop). Some residual water will drain during plug removal.
2. Clean strainer as needed using clean water.
3. Cartridge replacement - insert diamond end of the universal tool into push button, rotate 90 degrees and pull firmly to remove the button. Remove cartridge retaining nut . Remove and replace cartridge. When replacing cartridge be sure to align the inlet and outlet ports on the cartridge with the ports in the valve body.

• **NOTE: STRAINER SCREEN MUST BE IN PLACE FOR WATER TO FLOW.**

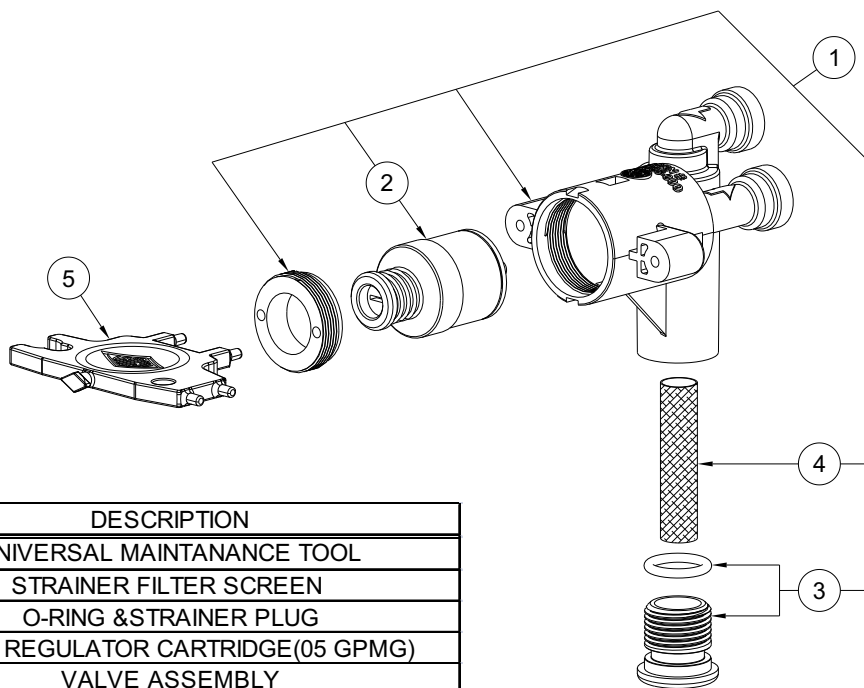

ITEM	PART NUMBER	DESCRIPTION
5	7003-830-000	UNIVERSAL MAINTANANCE TOOL
4	7003-864-000	STRAINER FILTER SCREEN
3	7003-097-001	O-RING & STRAINER PLUG
2	7000-060-000	FLOW REGULATOR CARTRIDGE(05 GPMG)
1	7003-095-001	VALVE ASSEMBLY



WATER COOLERS

INSTALLATION/MAINTENANCE INSTRUCTIONS

PUSH-IN FITTING INSTALLATION

NOTE: FITTINGS AND TUBE SHOULD BE KEPT CLEAN, BAGGED AND UNDAMAGED PRIOR TO INSTALLATION.

TO CUT TUBE:

Cut to fit length of 1/4" PE tubing and remove any burrs or sharp edges. Ensure that the outside diameter is free from score marks. Tube ends should be square.

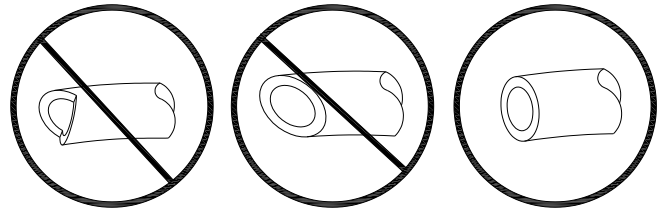

INSERTING THE TUBE:

1. Firmly and fully insert the tubing end into the push-in fitting up to the tube stop located approximately 1/2" deep.

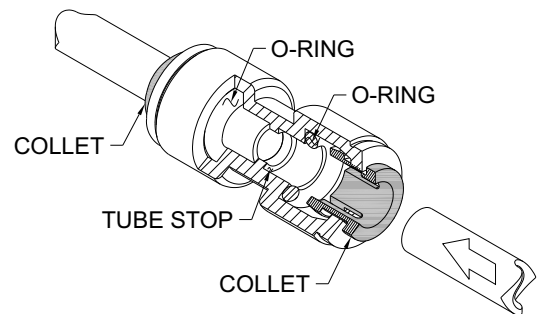

2. Pull on the fitted tubing to ensure it is secure. Tube should not come free from the fitting. Water test the connection assembly prior to leaving the site to ensure there are no leaks.

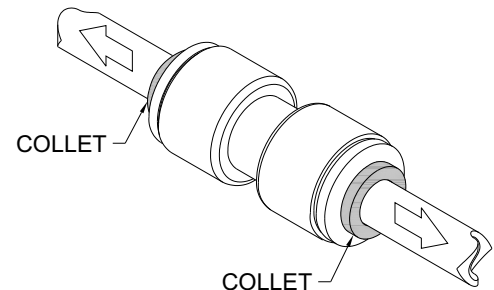

DISCONNECTING THE TUBE:

To disconnect the tube from the fitting ensure that the water line is depressurized. Push collet square towards the push-in fitting body and hold. While holding the collet in, pull on the PE tubing to remove from the push-in fitting.

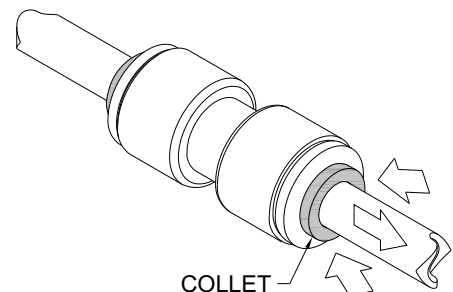



WATER COOLERS

INSTALLATION/MAINTENANCE INSTRUCTIONS

WATER COOLER PARTS BREAKDOWN DRAWING:

NOTE: See page 11 for table of part numbers corresponding to drawing below.

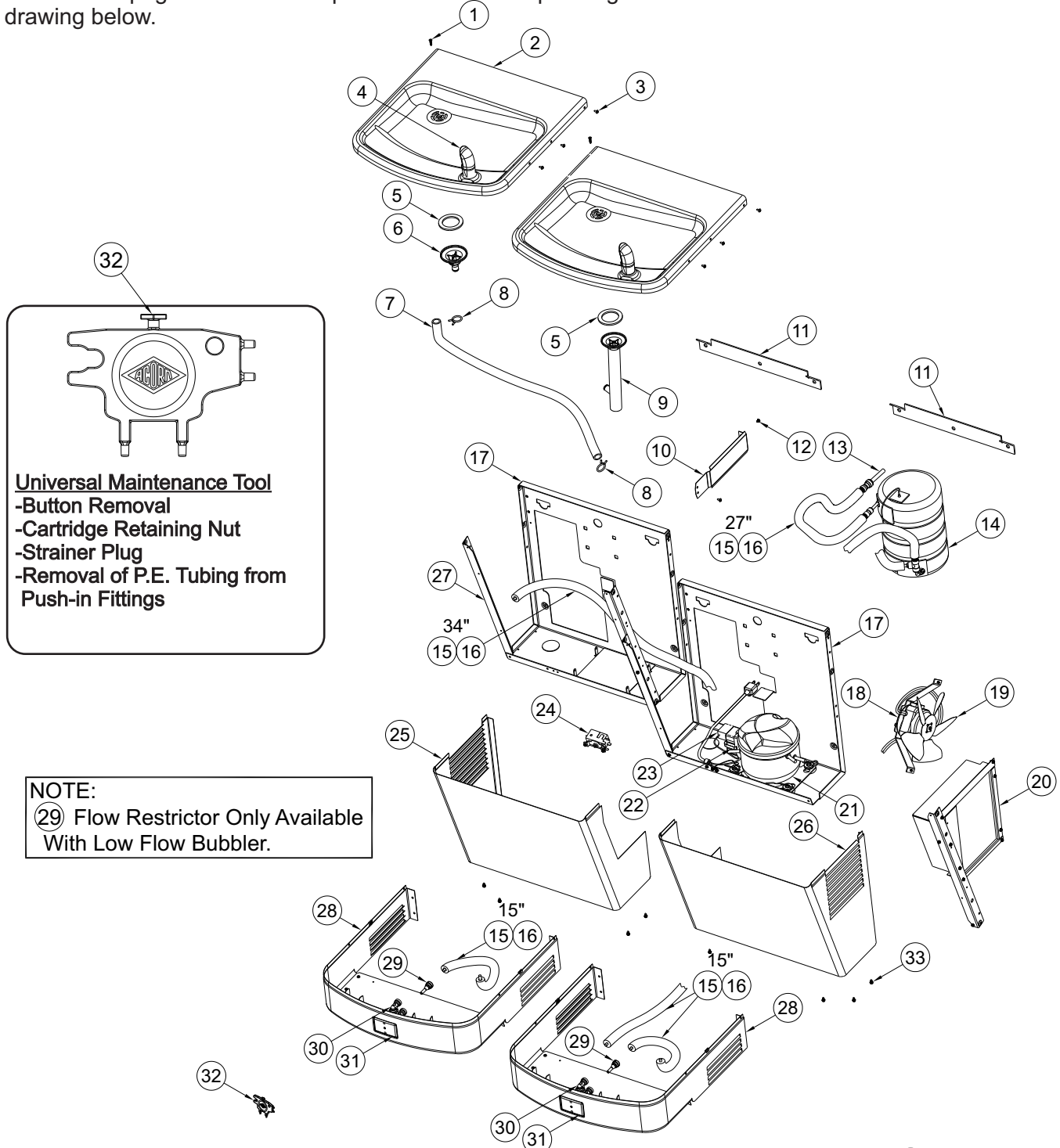

Universal Maintenance Tool
 -Button Removal
 -Cartridge Retaining Nut
 -Strainer Plug
 -Removal of P.E. Tubing from Push-in Fittings

NOTE:
 (29) Flow Restrictor Only Available With Low Flow Bubbler.

Standard A172.8UBL series refrigerated ADA cooler shown. All 1/4" O.D. Plastic tubing (15) must be insulated with (16) foam insulation.



WATER COOLERS

INSTALLATION/MAINTENANCE INSTRUCTIONS

SENSOR OPERATED WATER COOLER PARTS BREAKDOWN DRAWING:

NOTE: See page 11 for table of part numbers corresponding to drawing below.

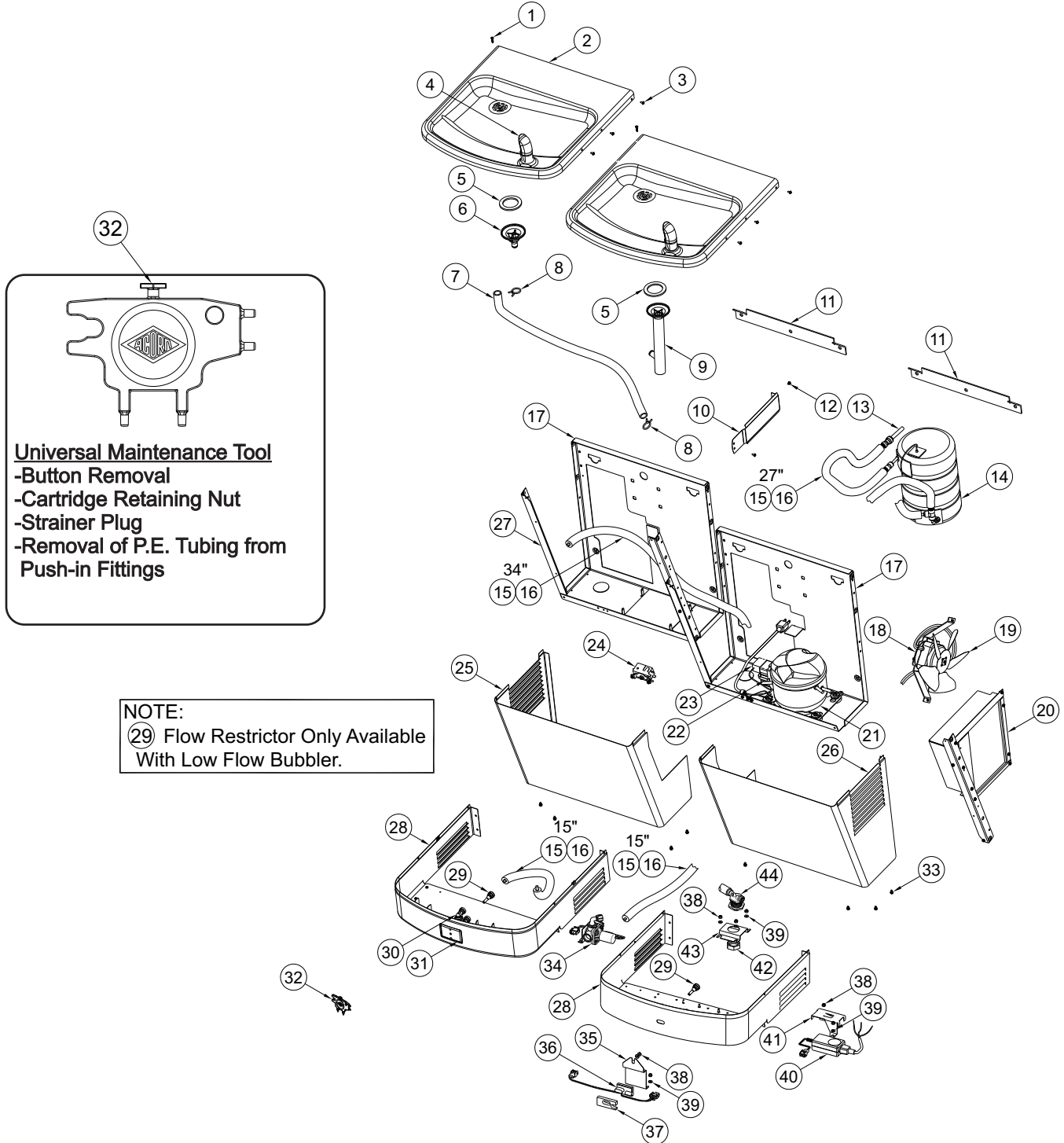

Repairs must be made with Acorn Engineering parts only. Please order through your local representative or distributor. The phone number to locate your local representative is 1.800.591.9360.



WATER COOLERS

INSTALLATION/MAINTENANCE INSTRUCTIONS

COOLER PARTS BREAKDOWN TABLE

NOTE: See previous page for fixture drawing corresponding to table of parts below.

ITEM#	PART NUMBER	DESCRIPTION
1	0124-032-000	#8 x 3/4" LG PHIL FLAT HD SELF TAPPING SCREW
2	7003-099-002	BASIN TOP
3	0124-056-000	#8 x 3/8" LONG PHILLIP HEAD SHEET METAL SCREW
4	7000-099-002	LOW-FLOW FLEXIBLE BUBBLER ASSEMBLY
	7000-012-001	STAINLESS STEEL BUBBLER ASSEMBLY
5	7000-006-000	FLAT DRAIN GASKET
6	7003-182-000	DRAIN TAIL PIECE (SHORT)
7	7003-183-199	DRAIN HOSE
8	7003-184-000	7/8" SPRING HOSE CLAMP
9	7003-181-000	DRAIN TAIL PIECE (LONG)
10	7003-819-020	FILLER PLATE - GRANITE
	7003-825-199	FILLER PLATE - STAINLESS STEEL
11	7003-014-199	HANGER BRACKET
12	0124-050-000	#8 x 3/8" LONG PHILLIPS PAN HEAD SCREW
13	1895-123-000	1/4" OD x 3/8" OD PUSH-IN CONNECTION
14	7003-115-001	EVAPORATOR ASSEMBLY
15	2169-000-000	1/4" OD TUBING
16	7012-055-000	TUBE INSLULATION
17	7003-003-199	BACK PANEL
18	7003-302-000	FAN MOTOR
	7012-062-001	FAN MOTOR - 220V
19	7003-350-000	FAN BLADE
20	7003-201-000	CONDENSER
21	7012-801-000	COMPRESSOR
	7012-030-001	COMPRESSOR - 220V
22	7012-802-000	START RELAY
	7012-031-000	START RELAY - 220V
23	7012-803-000	START CAPACITOR
	7012-032-000	START CAPACITOR - 220V
24	7003-250-000	COLD CONTROL
25	7003-817-020	LEFT CABINET - GRANITE
	7003-823-299	LEFT CABINET - STAINLESS STEEL
26	7003-818-020	RIGHT CABINET - GRANITE
	7003-824-299	RIGHT CABINET - STAINLESS STEEL
27	7003-007-199	SUPPORT STRUT
28	7003-816-020	APRON ASSEMBLY - GRANITE
	7003-826-001	APRON ASSEMBLY - STAINLESS STEEL
	7003-029-020	SENSOR OP APRON ASSEMBLY - GRANITE
	7003-029-005	SENSOR OP APRON ASSEMBLY - STAINLESS STEEL
29	7003-093-001	FLOW RESTRICTOR - LOW-FLOW BUBBLER ONLY
30	7003-095-001	VALVE ASSEMBLY
31	7003-099-000	PUSH BUTTON
32	7003-830-000	UNIVERSAL MAINTENANCE TOOL
33	0124-031-000	#8 x 3/8 LNG SLOTTED HEX WASHER HD SCREW
34	7001-200-001	SOLENOID/VALVE MOUNTING ASSEMBLY
35	7003-027-199	SENSOR BRACKET, SENSOR OP
36	2562-369-001	9VDC SENSOR
37	7001-202-199	SENSOR SPACER
38	0308-009-000	#8-32 NYLON INSERT LOCKNUT
39	0331-023-000	#8 S/S FLAT WASHER
40	0711-407-199	POWER SUPPLY, 240VDC
41	7003-028-199	TRANSFORMER BRACKET
42	7000-059-199	1-1/4" - 18 NORMALLY OPEN VALVE CAP
43	7003-023-199	CARTRIDGE MTG BRACKET, SENSOR OP
44	7000-050-001	VALVE CARTRIDGE ASSEMBLY

Repairs must be made with Acorn Engineering parts only. Please order through your local representative or distributor. The phone number to locate your local representative is 1.800.591.9360.

MURDOCK MFG. • 15125 Proctor Avenue • City of Industry, CA 91746 USA
 Phone 800-453-7465 or 626-333-2543 • Fax 626-855-4860 • www.murdockmfg.com

Member of  MORRIS GROUP INTERNATIONAL