



# BOTTLE FILLER RETROFIT

## BF12R Bottle Filler Series

H<sub>2</sub>O TO GO!<sup>®</sup> RETROFIT DECK MOUNT  
SENSOR OPERATED BOTTLE FILLER

### STANDARD FEATURES

#### Bottle Filler

- ADA Compliant
- 100-Mesh Inlet Strainer
- 120VAC/9.0VDC Plug-In Transformer
- Hands-Free Sensor Operation
- 1 GPM Laminar Flow Nozzle
- 20 Second Maximum Run Time

#### Retrofit Basin

- Rear Sloped Basin w/ Hole
- Fits existing A171, A172, Water Cooler Series and others  
(Contact Factory for more information)

### SUGGESTED SPECIFICATIONS

#### Bottle Filler BF12R

Bottle Filling unit shall include Sensor operated activation with a 20 second maximum run time. Housing construction will be 20 gage Stainless Steel with a satin finish and will also include components manufactured from Antimicrobial, impact resistant ABS. Optional -BCD (Bottle Counter Display) indicates the quantity of 16 oz disposable Plastic Bottles saved from a land fill and also displays the Water Filter status. LED Lights illuminate the Bottle Fill area and brighten when a bottle is detected. Optional -WF1 has a 1500-gallon capacity, has NSF/ANSI 42 & 53 certification and reduces Lead content in the drinking water by 99%. Bottle Filler shall provide approximately 1 GPM flow rate with a Laminar Flow Spout to minimize splashing.

#### Retrofit Basin

Basin shall be constructed from 304 stainless steel and have an integral drain.



### MODEL:

(Must Specify)

- BF12R Sensor Operated Bottle Filler w/ Retrofit Basin

### OPTIONS

(additional costs may be incurred)

- BCD Bottle Counter Display
- WF1 1500-gallon capacity, NSF 42+53,1 micron Lead Reduction Filter (Note: Shipped loose for Assembly to Water Cooler)

Complies with the following standards:



Member of U.S. Green Building Council



Recyclable Product



Water Conserving Product

⚠ WARNING: Cancer and Reproductive Harm - [www.P65Warnings.ca.gov](http://www.P65Warnings.ca.gov)

MURDOCK MFG. • 15125 Proctor Avenue • City of Industry, CA 91746 USA  
Phone 800-453-7465 or 626-333-2543 • Fax 626-855-4860 • [www.murdockmfg.com](http://www.murdockmfg.com)

Member of MORRIS GROUP INTERNATIONAL



# BOTTLE FILLER RETROFIT

## BF12R Bottle Filler Series

H<sub>2</sub>O TO GO!® DECK MOUNT SENSOR OPERATED BOTTLE FILLER

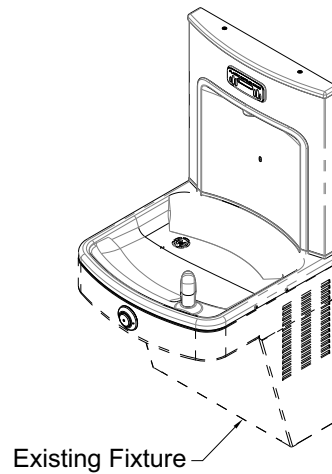
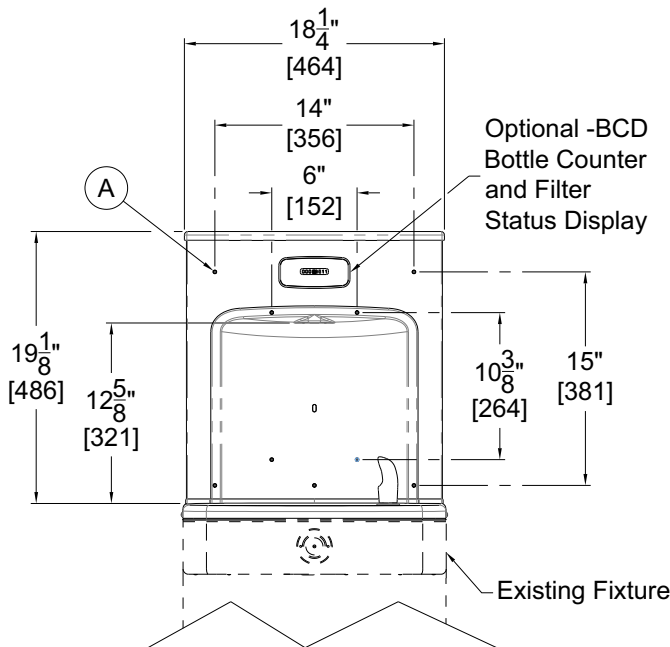
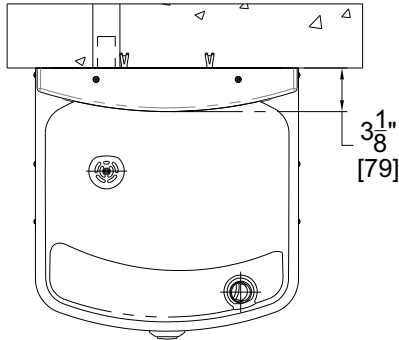

Existing Fixture

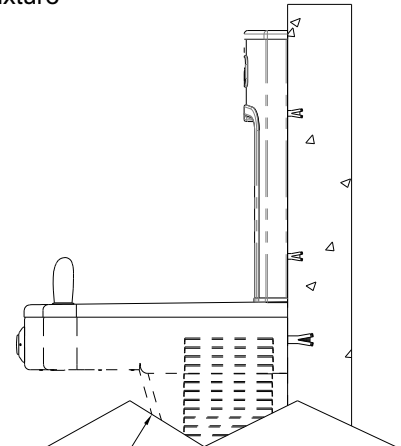

Existing Fixture

**General Note:**

- All dimensions are in inches [MM]

- A. Ø1/4" Holes, 10 Places for Anchoring Hardware, provided by others

Murdock Mfg.™ warrants that its products are free from defects in material or workmanship under normal use and service for a period of 18 months from date of shipment. The sealed refrigeration system is warranted for five years. Murdock's liability under this warranty shall be discharged solely by replacement or repair of defective material, provided Murdock™ is notified in writing within one year from date of shipment, F.O.B. Industry, California.

|  |  |                |  |
|--|--|----------------|--|
| SELECTION SUMMARY & APPROVAL FOR MANUFACTURING | Model Number & Options _____                 | Quantity _____ | All dimensions are subject to manufactures tolerance of plus or minus 1/2" nominal and subject to change without notice. Murdock assumes no responsibility for use of void or superseded data. Dimensions may change with the addition of optional accessories. Murdock Mfg.™, Member of Morris Group International™. Please visit <a href="http://www.murdockmfg.com">www.murdockmfg.com</a> for most current specifications. |
|  | Company _____                                |                |  |
|  | Contact _____                                | Title _____    |  |
|  | Signature (Approval for Manufacturing) _____ | Date _____     |  |